

Bölüm 6
SOĞUTMA ÇEVİRİMLERİ VE
SİSTEMLERİ

Ceyhun Yılmaz

Afyon Kocatepe Üniversitesi

Teknoloji Fakültesi Makine Mühendisliği Bölümü

3.1 Introduction

- **Soğutma:** The process of removing heat from matter which may be a solid, a liquid, or a gas.
- Removing heat from the matter cools it, or lowers its temperature.
- **Two common methods of refrigeration are natural and mechanical.**
- In the **natural refrigeration**, ice has been used. The forced circulation of air passes around blocks of ice. Some of the heat of the circulating air is transferred to the ice, thus cooling the air, particularly for A-C applications.
- In the **mechanical refrigeration** a refrigerant is used. By means of expansion, compression, and a cooling medium, such as air or water, the refrigerant removes heat from a substance and transfers it to the cooling medium.
- **Refrigeration applications:** Used in industry for cooling and freezing of products, condensing vapors, maintaining environmental conditions and for cold storage.
- The number of different applications is huge and they are a major consumer of electricity. In some sectors, particularly food, drink and chemicals it represents a significant proportion of overall site energy costs (up to 90% in the case of some cold storage facilities).

- Presently, the refrigeration industry urgently needs
 - technical information on the refrigeration systems, system components, and technical and operational aspects of such systems and components;
 - procedures for energy and exergy analyses of refrigeration systems for system design and optimization;
 - application of optimum refrigeration techniques;
 - techniques for the measurement and evaluation of the components' performance;
 - methodology for the use of the cooling data to design an efficient and effective refrigeration system and/or to improve the existing refrigeration systems.
- The primary objective of this chapter is to discuss refrigeration cycles and their energy and exergy analyses, major refrigeration system components (e.g. compressors, condensers, evaporators, throttling devices) and their technical and operational aspects, auxiliary refrigeration system components, some new refrigeration techniques for more efficient and effective refrigeration.

3.2 History of Refrigeration

- At least as early as the second century evaporation was used in Egypt to chill jars of water, and it was employed in ancient India to make ice.
- In 1755 William Cullen, a Scottish physician, obtained sufficiently low temperatures for ice making by reducing the pressure on water in a closed container with an air pump.
- In 1834, Jacob Perkins, an American, constructed and patented a vapor-compression machine with a compressor, a condenser, an evaporator, and a cock.
- Dr. John Gorrie, an American, developed a real commercial cold-air machine and patented it in England in 1850.
- In 1860, a French engineer, Ferdinand P. Edmond Carre, invented an intermittent crude ammonia absorption apparatus, which produced ice on a limited scale.
- Between 1880 and 1890 ammonia-compression installations became more common.
- By 1890 mechanical refrigeration had proved to be both practical and economical for the food refrigeration industry.

3.3 Main Refrigeration Systems and Cycles

- The main goal of a refrigeration system which performs the reverse effect of a heat engine is to remove the heat from a low-level temperature medium (*heat source*) and to transfer this heat to a higher level temperature medium (*heat sink*).

Main refrigeration systems and cycles

- buhar sıkıştırırmalı soğutma sistemleri
- soğurmalı soğutma sistemleri
- hava-standart soğutma sistemleri
- jet fırlatma soğutma sistemleri
- termoelektrik soğutma
- thermoacoustic soğutma.

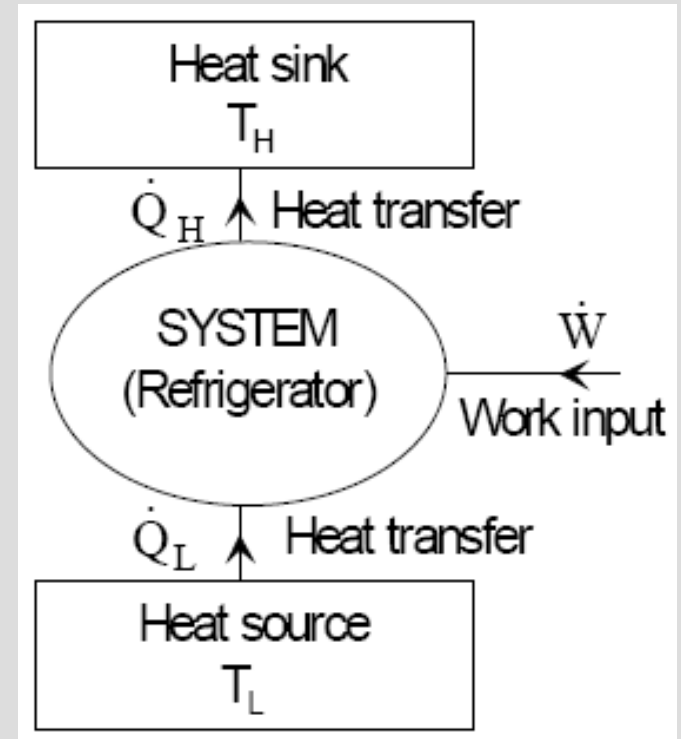

Figure 3.1 A thermodynamic system acting as a refrigerator.

3.4 Soğutma Sistemi Elemanları

Major components of a vapor-compression refrigeration system are

- kompresör, kondenser, evaporatör, ve genişleme vanası.

In the selection of any component for a refrigeration system, there are a number of factors that need to be considered carefully, including

- maintaining total refrigeration availability while the load varies from 0 to 100%;
- frost control for continuous performance applications;
- variations in the affinity of oil for refrigerant caused by large temperature changes, and oil migration outside the compressor crankcase;
- selection of cooling medium: (i) direct expansion refrigerant, (ii) gravity or pump recirculated or flooded refrigerant, or (iii) secondary coolant (brines, e.g., salt and glycol);
- system efficiency and maintainability;
- type of condenser: air, water, or evaporatively cooled;
- compressor design (open, hermetic, semihermetic motor drive, reciprocating, screw, or rotary);
- system type (single stage, single economized, compound or cascade arrangement); and
- selection of refrigerant (note that the type of refrigerant is basically chosen based on operating temperature and pressures).

3.5 Kompresörler

- In a refrigeration cycle, the compressor has two main functions within the refrigeration cycle.
- **One function** is to pump the refrigerant vapor from the evaporator so that the desired temperature and pressure can be maintained in the evaporator.
- The **second function** is to increase the pressure of the refrigerant vapor through the process of compression, and simultaneously increase the temperature of the refrigerant vapor.
- Refrigerant compressors, which are known as **the heart of the vapor-compression refrigeration systems**, can be divided into two main categories:
 - **Pozitif Sıkıştırılmalı Kompresörler (pistonlu kompresörler) ve**
 - **Santrifüj (Turbo) Kompresörler (dinamik kompresörler).**

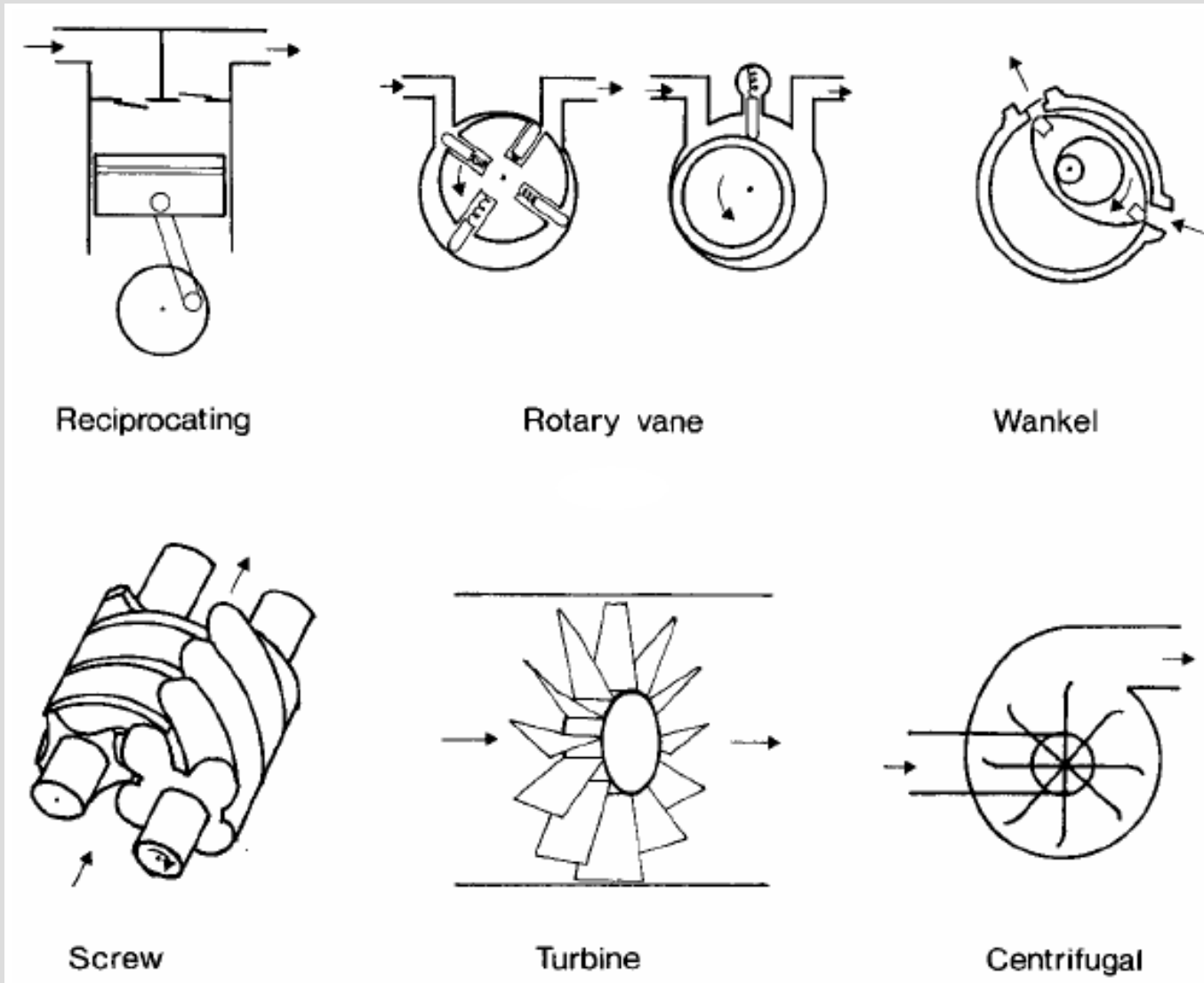

Figure 3.2 Compressor tipleri

- Both displacement and dynamic compressors can be **hermetic**, **semihermetic**, or **open types**.
- The compressor both pumps refrigerant round the circuit and produces the required substantial increase in the pressure of the refrigerant.
- The refrigerant chosen and the operating temperature range needed for heat pumping generally lead to a need for a compressor to provide **a high pressure difference for moderate flow rates**, and **this is most often met by a positive displacement compressor using a reciprocating piston**.
- Other types of positive displacement compressor use rotating vanes or cylinders or intermeshing screws to move the refrigerant.
- In some larger applications, centrifugal or turbine compressors are used, which are not positive displacement machines but accelerate the refrigerant vapor as it passes through the compressor housing.

In the market, there are many different types of compressors available, in terms of both enclosure type and compression system. Here are some options for evaluating the most common types (DETR, 1999):

- **Reciprocating compressors** are positive displacement machines, available for every application. The efficiency of the valve systems has been improved significantly on many larger models. Capacity control is usually by cylinder unloading (a method which reduces the power consumption almost in line with the capacity).
- **Scroll compressors** are rotary positive displacement machines with a constant volume ratio. They have good efficiencies for air conditioning and high-temperature refrigeration applications. They are only available for commercial applications and do not usually have inbuilt capacity control.
- **Screw (Helisel vidalı) compressors** are available in large commercial and industrial sizes and are generally fixed volume ratio machines. Selection of a compressor with the incorrect volume ratio can result in a significant reduction in efficiency. Part-load operation is achieved by a slide valve or lift valve unloading. Both types give a greater reduction in efficiency on part load than the reciprocating capacity control systems.

Kompresörlerden beklenenler:

Soğutmada kompresörlerden aşağıdaki gereksinimleri karşılaması beklenir:

- yüksek güvenilirlik
- uzun ömürlü olması
- kolay bakım sağlanabilmesi
- kolay kapasite kontrolü
- sessiz çalışması
- yoğunluk
- ve düşük maliyet.

Kompresör seçim kriterleri:

Uygun bir soğutucu kompresör seçiminde aşağıdaki kriterler dikkate alınır:

- soğutma kapasitesi
- hacimsel debi
- sıkıştırma oranı
- ve soğutucunun termal ve fiziksel özellikleri

3.5.1 Hermetik kompresörler

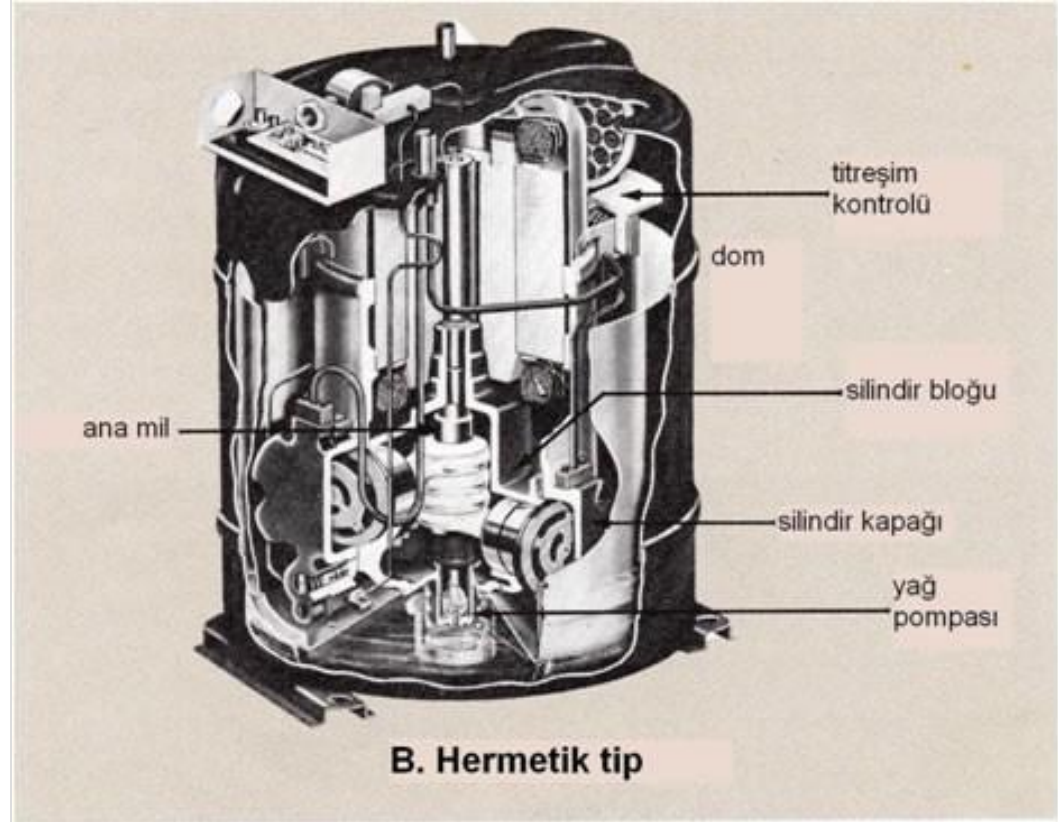
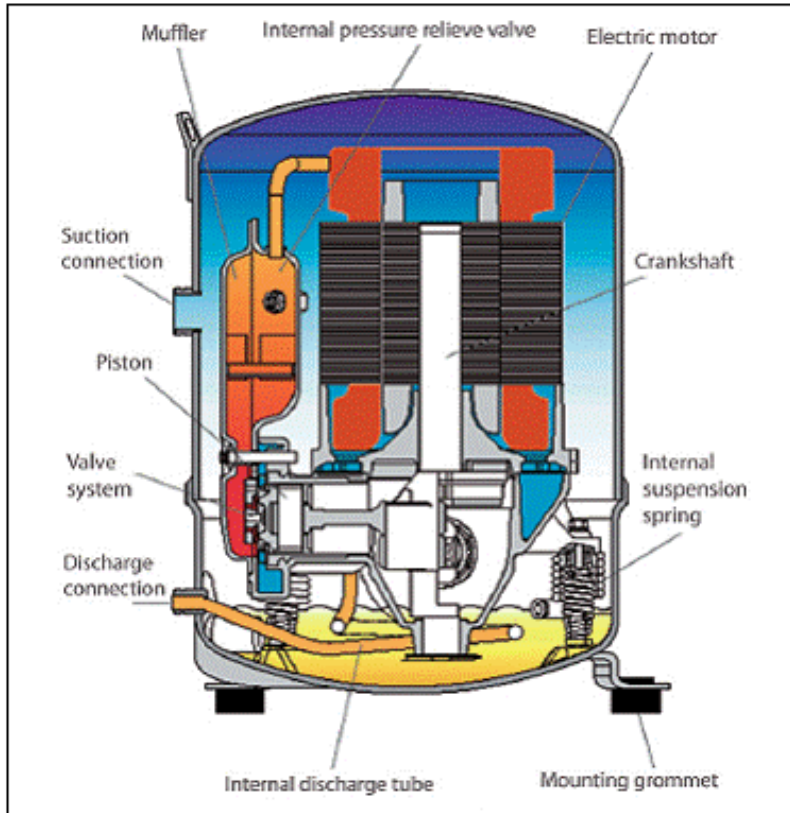

Figure 3.3 A typical hermetic reciprocating compressor

- In these compressors, which are available for small capacities, motor and drive are sealed in compact welded housing.
- The refrigerant and lubricating oil are contained in this housing.
- Almost all small motor-compressor pairs used in domestic refrigerators, freezers, and air conditioners are of the hermetic type.
- The capacities of these compressors are identified with their motor capacities.
- For example, the compressor capacity ranges from 1/12 HP to 30 BG in household refrigerators.
- Their revolutions per minute are either 1450 or 2800 rpm.
- Hermetic compressors can work for a long time in small-capacity refrigeration systems without any maintenance requirement and without any gas leakage, but they are sensitive to electric voltage fluctuations.
- The cost of these compressors is very low.

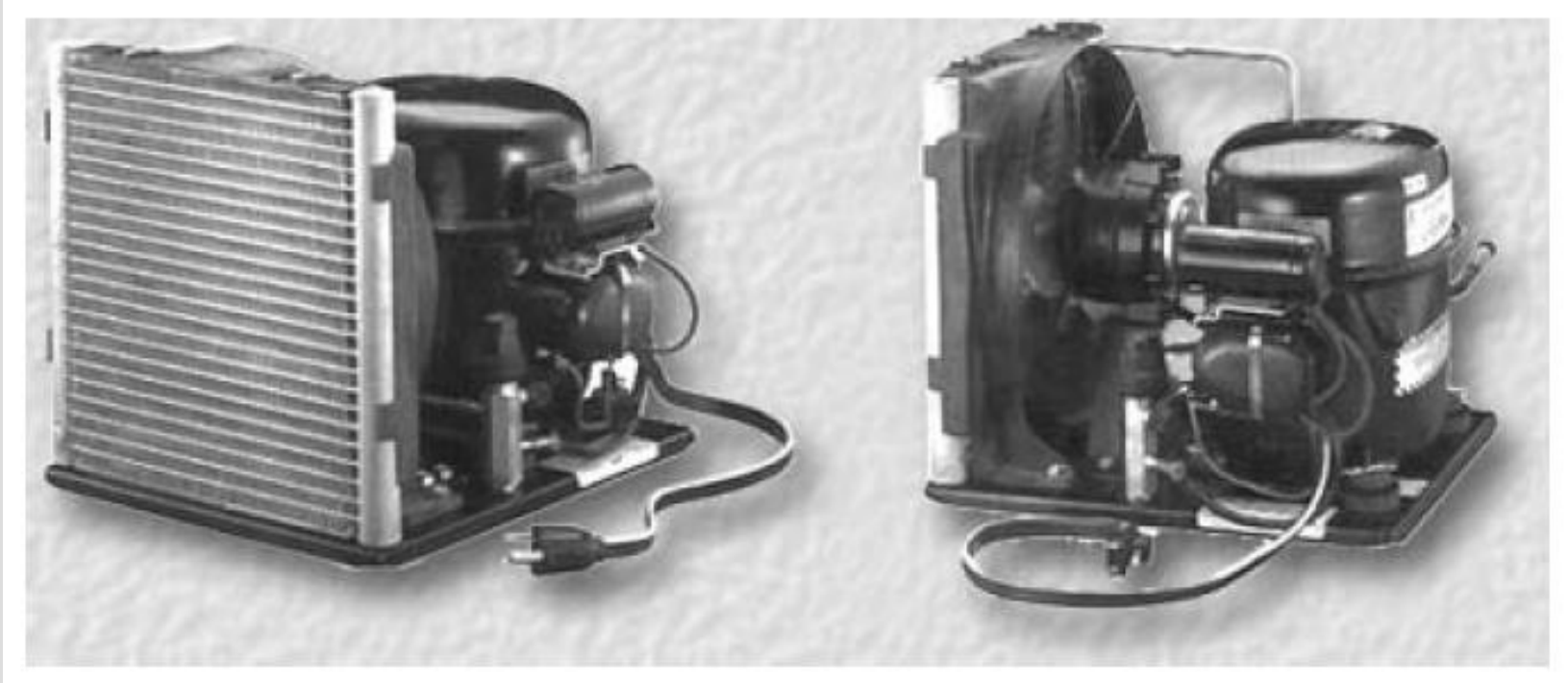

Figure 3.4 New, high-efficient compact coil air-cooled condensing units using hermetic compressors

3.5.2 Semihermetic compressors

- In larger sizes, refrigeration compressors are often semihermetic,
- Semihermetic compressors are identical to the hermetic types, but the motor and compressor are constructed in a fabricated enclosure with bolted sections or access panels to facilitate servicing.
- The cost is substantially higher than for hermetic units.
- Overall efficiencies of up to 70% or more are theoretically possible.
- These compressors are manufactured in small and medium capacities and their motor capacities can reach 300 kW.
- They are compact and they do not have a leakage problem.
- These compressors are available for alternative refrigerants (e.g. R-134a, R-404A and R-507).

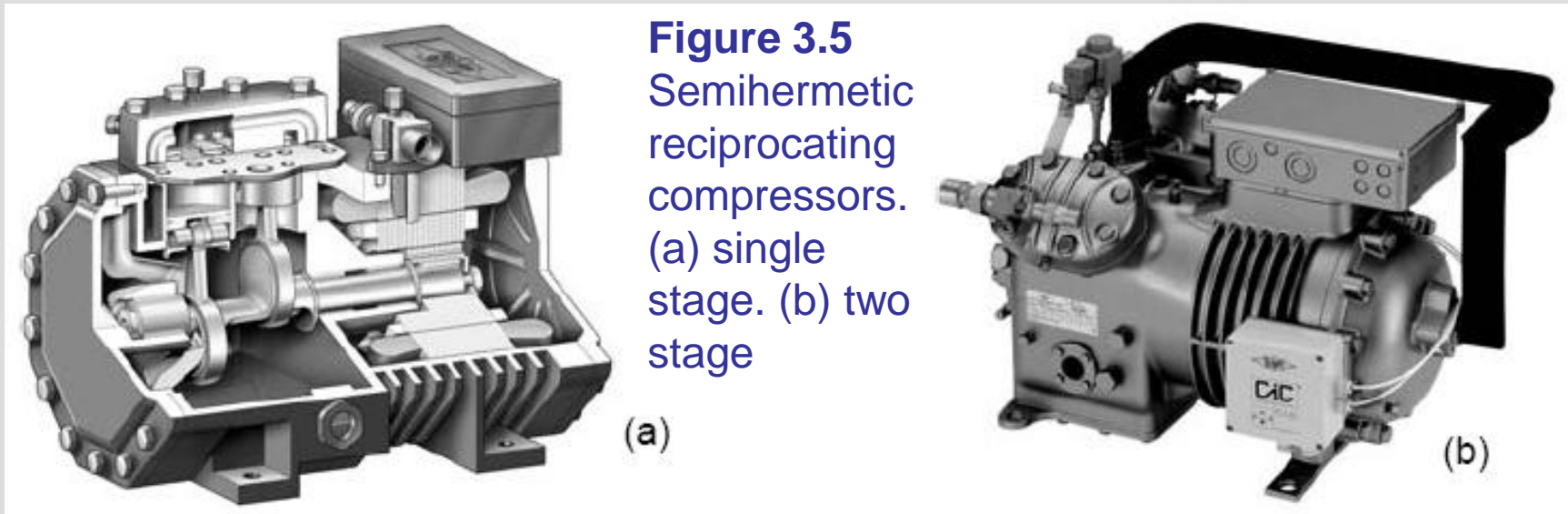

Figure 3.5a shows the cutaway view of a single-stage octagon series semihermetic reciprocating compressor with nominal motor powers of 60 and 70 hp.

Figure 3.5b shows a two-stage semihermetic reciprocating compressor for extremely low temperature applications and its main feature is the two-stage compression in one housing.

Particularly for commercial refrigeration applications with high load variations, an energy efficient operation at full and part load (up to four capacity stages) with all common refrigerants is possible at reasonable cost.

3.5.3 Açık Kompresörler

Open reciprocating compressors with a shaft seal and an external drive motor suitable for a range of prime movers are also available up to about 2 MW duty.

In these compressors, the crankshafts, which are externally coupled with electric motors, extend through the compressor housings.



Figure 3.6 (a) Open type reciprocating compressor and (b) air-cooled condensing unit with an open type reciprocating compressor

3.5.4 Displacement compressors

- These compressors use the shaft work to increase the refrigerant pressure by reducing the compression volume in the chamber.
- The compressors of this group are
 - reciprocating,
 - vane (rotary),
 - screw (helical rotary)

Reciprocating compressors

A great majority of reciprocating compressors which compress the refrigerant gas only on the forward stroke of a piston are built to be single acting in a large capacity range, up to hundreds of kilowatts.

Models of these compressors may be single-cylinder or multicylinder in V, W, radial, or line form.



Figure 3.7 An internal view of V-type 6-cylinder reciprocating compressor

- The power required for the compressor can be provided either directly by a motor or indirectly by a belt or a gear drive.
- In these compressors, **cylinder clearance volume, compression ratio, amount of suction superheat, valve pressure drops, and the refrigerant-oil characteristics** are the main parameters which affect their efficiencies.
- The selection of cooling method is dependent on the discharge temperature.
 - For example, when the discharge temperature is low, as in R-134a compressors, **air cooling** is usually chosen.
 - **Water cooling** is used where high discharge temperatures occur.

Rotary compressors

- Rotary compressors are of four general design configurations:
 - (i) rolling piston, (ii) rotating vane, (iii) screw, and (iv) scroll.
- Rotary compressors have a rotary or circular motion instead of a reciprocating motion.
- They operate on rotors which rotate on an eccentric shaft. Gas enters through a space between the rotor and the cylinder through a suction port.
- The gas is compressed as the rotor revolves due to the eccentric assembly of the rotor and the cylinder.
- A discharge port on the opposite releases the compressed air.
- The two more commonly used rotary compressors include
 - the rolling piston-type and the rotating-vane-type.
- Both are very similar in size, performance and applications.
- Rotary compressors are popular in domestic refrigeration and suited for applications where large volumes of vapor are circulated and where a low compression ratio is desired.

Vane compressors

- There are two major types of vane compressors, **single-vane (rotary)** and **multivane**.
- A rotary compressor simply consists of a bladed, eccentric rotor in a cavity.
- As the rotor turns, the blades extend and retract, sealing off the cavity into segments of varying size.
- The gas enters the intake port where the segments are large, is compressed as the cavities are reduced, and is discharged where the segments are small.
- These compressors are commonly used in **domestic refrigerators, freezers, and air conditioners**.
- The possible maximum compression ratios achieved are on the order of 7:1.
- Small systems and some ammonia systems also employ compressors of this type.



Figure 3.8 Cutaway view of a rotary vane compressor

Basic advantages of vane compressors

- **Simple, compact design.** Sturdy construction with few moving parts, easy to access and maintain, easy to replace parts, very reliable, and durable.
- **Single-stage compression.** The nature of the design produces sufficient compression in a single stage, resulting in a very high-compression ratio during cycle, as well as better energy efficiency, reduced risk of fault, and reduced maintenance requirements.
- **Direct axial coupling to the motor.** Direct coupling is possible because the high-compression ratio permits low-rotation speeds, eliminating the need for transmission or gears. Fewer parts mean lower energy dissipation and simplified maintenance.
- **Low-rotation speeds.** Lower speeds reduce vibration, thus diminishing noise and wear, lowering temperature, and eliminating the need for foundations.
- **Low cycle temperature.** Lower temperatures reduce wear, oil consumption, and leakage caused by distension of parts. Less energy is needed for cooling and the purity of delivered air is enhanced.
- **Low need for maintenance.** With fewer parts suffering little wear, single-stage rotary vane units offer cleaner and more reliable operation, significantly reducing maintenance needs.

Screw compressors

- Screw compressor technology offers many benefits over reciprocating types, including higher reliability and improved performance.
- Screw compressors are also positive displacement refrigeration system components.
- Both single screw and twin screw compressors are widely used in refrigeration applications.
- A single screw compressor consists of a single helical rotor (shaft) and a pair of gate rotors, that then mesh together and with the casing form a sealed volume wherein compression takes place.

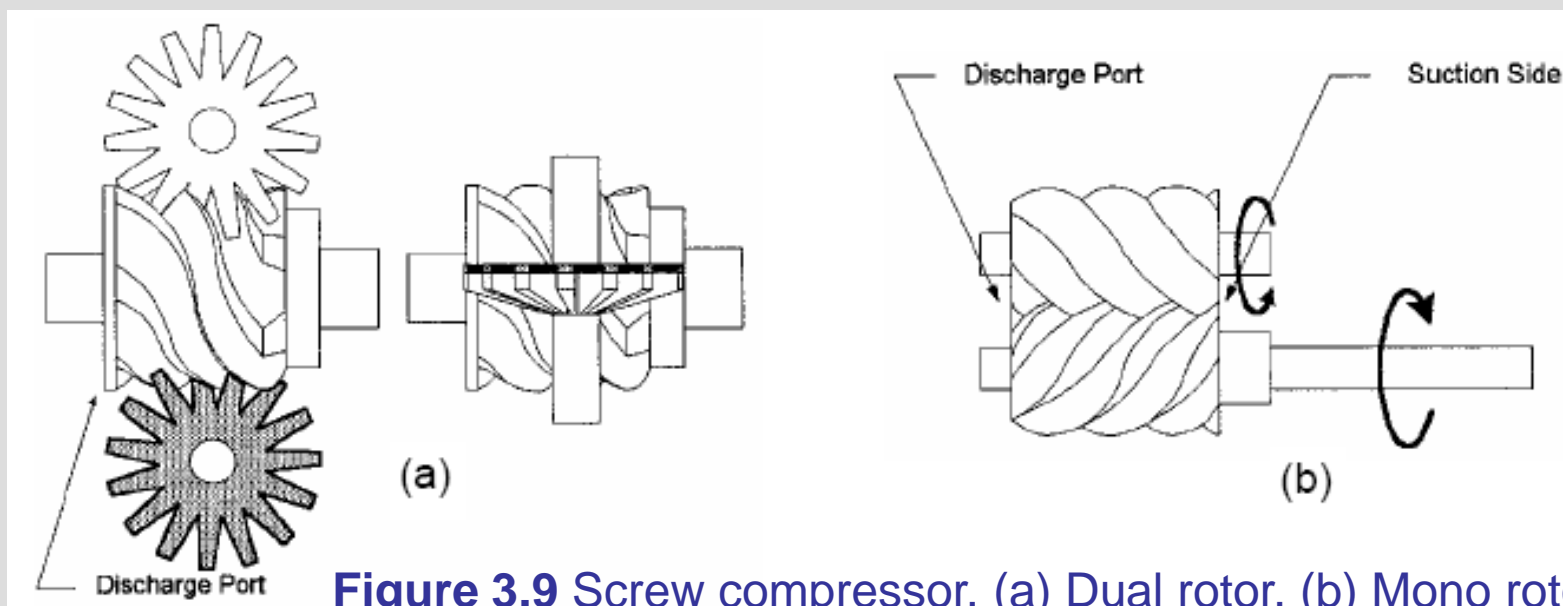

Figure 3.9 Screw compressor. (a) Dual rotor. (b) Mono rotor

- The screw compressors were developed specifically for use in applications of -40°C and below (down to -50°C).
- The development of this advanced screw-style refrigeration system offers the following benefits:
 - better performance per hp,
 - improved reliability,
 - reduced costs,
 - fewer moving parts,
 - less vibration,
 - less refrigerant loss.
- By design and function, the screw compressor has far fewer moving parts than the reciprocating style.

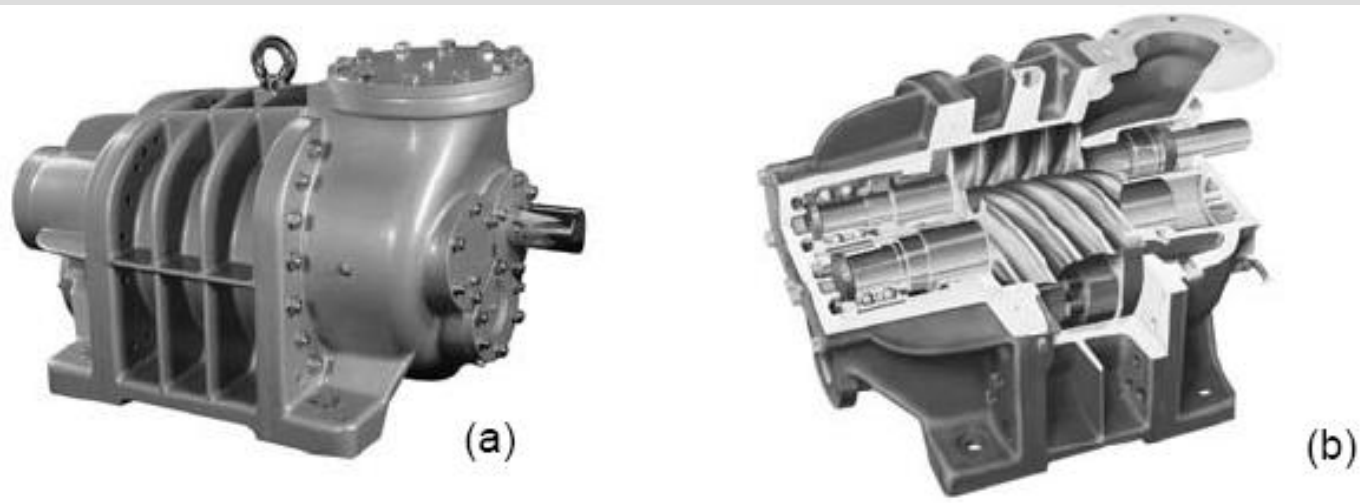

Figure 3.10 A large capacity double-screw compressor.
(a) Complete view
(b) Internal view

- For industrial refrigeration applications, such as process chillers, the high-temperature compact screw compressors provide an ideal solution.
- The integrated oil separator and oil reservoir significantly reduces the installation time, complexity, cost and space required.
- Such compressors are available in sizes from 50–140 hp which are equipped with the dual capacity control system and auto-economizer and can be used with the common refrigerants R-134a, R-407C, and R-22 (R-404A, R-507A in special applications).
- Figure 3.11 shows the cutaway view of a hermetic rotary type screw compressor which is commonly used in small-scale refrigeration applications, particularly in household and commercial units.



Figure 3.11 Internal view of a hermetic rotary screw compressor

Scroll compressors

- The scroll compressor uses one stationary (fixed) and one orbiting scroll to compress refrigerant gas vapors from the evaporator to the condenser of the refrigerant path.
- Scroll compressors are a relatively recent compressor development and are expected to eventually replace reciprocating compressors in many cooling system applications, where they often achieve higher efficiency and better part-load performance and operating characteristics.

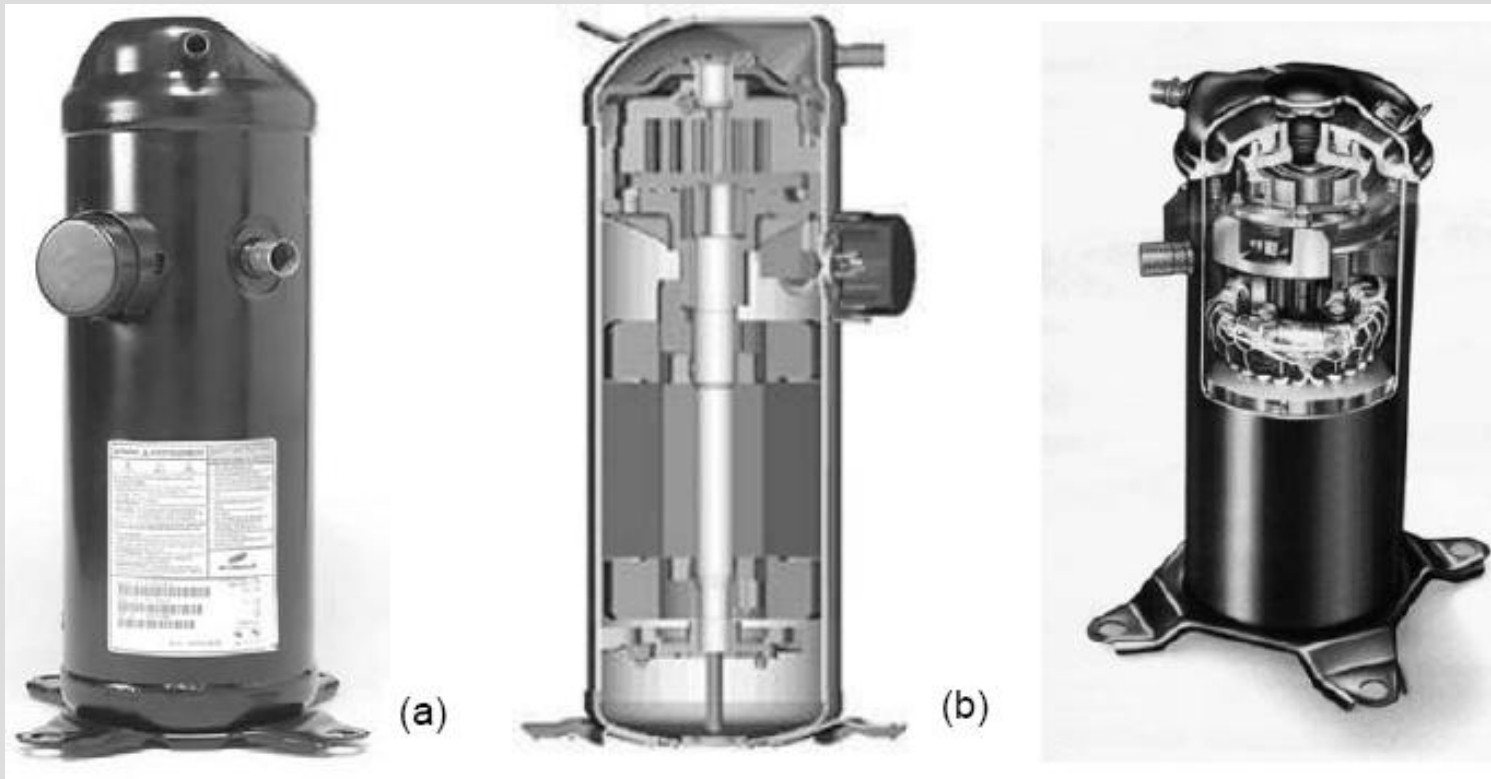

Figure 3.12 A hermetic scroll compressor. (a) Complete view. (b) Cutaway view. (c) Internal view

3.5.5 Dynamic compressors

- These compressors increase the refrigerant pressure through a continuous exchange of angular momentum between a rotating mechanical element and the fluid subject to compression.
- The main types are **centrifugal** and **turbo** compressors.

Centrifugal compressors

- Centrifugal compressors are often used in place of positive displacement compressors for very large capacities, or for high-flow low-pressure difference applications, and are available, designed for refrigeration use, in the 300 kW-20 MW range (e.g. 400–10,000 tons).
- They are also appropriate for multi-stage refrigeration applications.



Figure 3.13

(a) Cutaway view of a centrifugal compressor.
(b) A chiller unit with centrifugal compressor

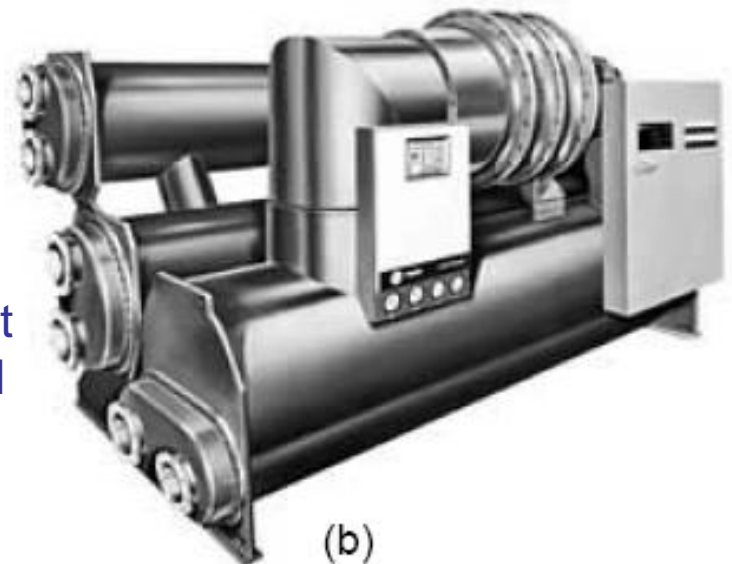

(a)

(b)

- The centrifugal compressors available in the market use R-123, R-22 and R-134a.
- This usually calls for semihermetic designs, with single or multi-stage impellers.
- In refrigeration industry multi-stage centrifugal compressors are now manufactured with cast iron, nodular iron and cast steel casings for discharge pressures up to 40 bar.
- With up to eight wheels in a single casing, the compressor has a capacity of 42,000 m³/h and 9000 kW.



Figure 3.14 A centrifugal compressor

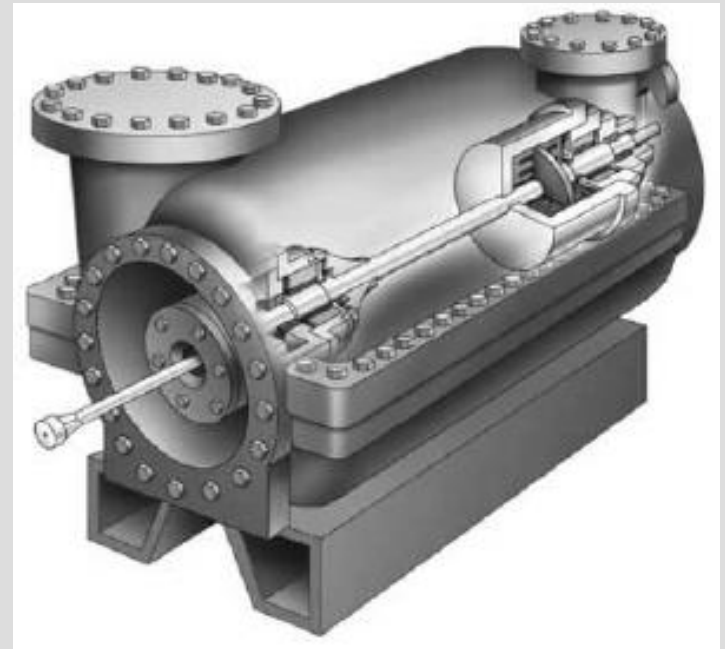

Figure 3.15 Cutaway view of a centrifugal compressor using magnetic bearings

Turbo (Santrifüj) compressors

- In refrigeration technology, turbo compressors usually denote centrifugal compressors, but their efficiencies are low.
- In this type of compressor, the discharge pressure is limited by the maximum permitted tip speed.
- A set of impellers is arranged for high compression pressures.
- These compressors have found applications in air conditioning and water chilling systems where high suction volumes at high suction pressures are required.

Energy and Exergy Analysis of Compressors

Compressors are used to increase the pressure of a fluid. In the case of a refrigeration cycle, it is used to compress the refrigerant.

Compressors operate continuously and the compression process can be modeled as a steady-flow process.

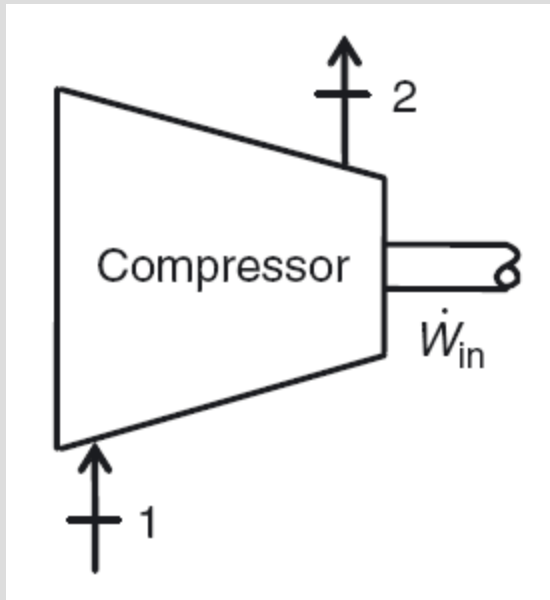

The schematic of a compressor considered for mass and energy analysis

$$\dot{m}_1 = \dot{m}_2 \longrightarrow \rho_1 A_1 V_1 = \rho_2 A_2 V_2$$

$$\longrightarrow \frac{1}{v_1} A_1 V_1 = \frac{1}{v_2} A_2 V_2 \longrightarrow \frac{\dot{V}_1}{v_1} = \frac{\dot{V}_2}{v_2}$$

\dot{m} : the mass flow rate (kg/s)

ρ : density (kg/m³)

A : cross-sectional area (m²)

V : velocity (m/s)

v : specific volume (m³/kg)

\dot{V} the volume flow rate (m³/s)

The steady-flow energy balance

$$\dot{E}_{in} = \dot{E}_{out}$$

$$\dot{W}_{in} + \dot{m} h_1 = \dot{m} h_2$$

$$\dot{W}_{in} = \dot{m} (h_2 - h_1)$$

Assuming that there is a net heat transfer from the compressor, the energy balance equation becomes

$$\dot{W}_{in} + \dot{m} h_1 = \dot{Q}_{out} + \dot{m} h_2$$

$$\dot{W}_{in} - \dot{Q}_{out} = \dot{m} (h_2 - h_1)$$

Entropy balance

$$\dot{S}_{in} - \dot{S}_{out} + \dot{S}_{gen} = \Delta \dot{S}_{sys} = 0$$

$$\dot{S}_{gen} = \dot{S}_{out} - \dot{S}_{in}$$

$$\dot{S}_{gen} = \dot{m} s_2 - \dot{m} s_1 = \dot{m} (s_2 - s_1)$$

the exergy destruction during the compression

$$\dot{E}x_{dest} = T_0 \dot{S}_{gen} = \dot{m} T_0 (s_2 - s_1)$$

The exergy destruction can also be determined by writing an exergy balance on the compressor

$$\dot{E}x_{in} - \dot{E}x_{out} - \dot{E}x_{dest} = 0$$

$$\dot{E}x_{dest} = \dot{E}x_{in} - \dot{E}x_{out}$$

$$\dot{E}x_{dest} = \dot{W} + \dot{E}x_1 - \dot{E}x_2$$

$$= \dot{W} - \Delta \dot{E}x_{12}$$

$$= \dot{W} - \dot{m} [h_2 - h_1 - T_0 (s_2 - s_1)]$$

$$= \dot{W} - \dot{W}_{rev}$$

the reversible work input to the compressor

$$\dot{W}_{rev} = \dot{E}x_2 - \dot{E}x_1 = \dot{m} [h_2 - h_1 - T_0 (s_2 - s_1)]$$

exergy efficiency of the compressor

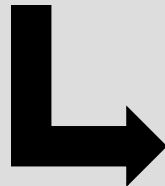

$$\eta_{ex,Comp} = \frac{\dot{W}_{rev}}{\dot{W}} = 1 - \frac{\dot{E}x_{dest}}{\dot{W}}$$

Example 3.1

Refrigerant-134a enters the compressor of a refrigeration cycle at 160 kPa and -10°C with a flow rate of $0.25\text{ m}^3/\text{min}$ and leaves at 900 kPa and 60°C . The ratio of the clearance volume to the displacement volume is 0.05. Determine (a) the volumetric efficiency of the compressor, (b) the power input to the compressor, (c) the isentropic efficiency of the compressor, and (d) the rate of exergy destruction and the exergy efficiency of the compressor. Take $T_0 = 25^{\circ}\text{C}$.

Solution

- (a) The properties of refrigerant at the inlet and exit states of the compressor are obtained from R-134a tables:

$$\left. \begin{array}{l} P_1 = 160 \text{ kPa} \\ T_1 = -10^{\circ}\text{C} \end{array} \right\} \begin{array}{l} h_1 = 245.77 \text{ kJ/kg} \\ s_1 = 0.9598 \text{ kJ/kg} \cdot \text{K} \\ v_1 = 0.1269 \text{ m}^3/\text{kg} \end{array}$$

$$\left. \begin{array}{l} P_2 = 900 \text{ kPa} \\ T_2 = 60^{\circ}\text{C} \end{array} \right\} \begin{array}{l} h_2 = 295.13 \text{ kJ/kg} \\ s_2 = 0.9976 \text{ kJ/kg} \cdot \text{K} \\ v_2 = 0.02615 \text{ m}^3/\text{kg} \end{array}$$

$$\left. \begin{array}{l} P_2 = 900 \text{ kPa} \\ s_2 = s_1 = 0.9598 \text{ kJ/kg} \cdot \text{K} \end{array} \right\} h_{2s} = 282.76 \text{ kJ/kg}$$

$$\eta_{\text{Comp,vol}} = 1 - R \left(\frac{v_1}{v_2} - 1 \right) = 1 - 0.05 \left(\frac{0.1269}{0.02615} - 1 \right) = \mathbf{0.807} = \mathbf{80.7\%}$$

(b) The mass flow rate of the refrigerant and the actual power input are

$$\dot{m} = \frac{\dot{V}_1}{v_1} = \frac{(0.25/60) \text{ m}^3/\text{s}}{0.1269 \text{ m}^3/\text{kg}} = 0.03285 \text{ kg/s}$$

$$\dot{W}_{\text{act}} = \dot{m}(h_2 - h_1) = (0.03285 \text{ kg/s})(295.13 - 245.77) \text{ kJ/kg} = \mathbf{1.621 \text{ kW}}$$

(c) The power input for the isentropic case and the isentropic efficiency are

$$\dot{W}_{\text{isen}} = \dot{m}(h_{2s} - h_1) = (0.03285 \text{ kg/s})(282.76 - 245.77) \text{ kJ/kg} = 1.215 \text{ kW}$$

$$\eta_{\text{Comp,isen}} = \frac{\dot{W}_{\text{isen}}}{\dot{W}_{\text{act}}} = \frac{1.215 \text{ kW}}{1.621 \text{ kW}} = \mathbf{0.749 = 74.9\%}$$

(d) The exergy destruction is

$$\dot{E}x_{\text{dest}} = \dot{m}T_0(s_2 - s_1) = (0.03285 \text{ kg/s})(298 \text{ K})(0.9976 - 0.9598) \text{ kJ/kg} \cdot \text{K} = \mathbf{0.370 \text{ kW}}$$

The reversible power and the exergy efficiency are

$$\dot{W}_{\text{rev}} = \dot{W}_{\text{act}} - \dot{E}x_{\text{dest}} = 1.621 - 0.370 = 1.251 \text{ kW}$$

$$\eta_{\text{Comp,ex}} = \frac{\dot{W}_{\text{rev}}}{\dot{W}_{\text{act}}} = \frac{1.251 \text{ kW}}{1.621 \text{ kW}} = \mathbf{0.772 = 77.2\%}$$

3.5.6 Compressor capacity and performance

- All compressors are rated in terms of how much flow they produce at a given ratio of outlet to inlet pressure (**compression ratio**).
- This flow is obviously a function of **compressor size** (e.g. the number of cylinders and volume displacement for reciprocating compressors) and **operating speed** (rpm).
- The limits of clearance volumes and valve pressure differentials force some of the compressor's flow volume capability to be lost as useful compression.
- This is referred to as **volumetric efficiency**.
- For example, at a compression ratio of 3 to 1, 82% of the volume of the compressor is useful.
- Thus, if the refrigeration effect required 10 cfm of vapor flow from the evaporator, the compressor would have to produce $10/0.82$ or 12.2 cfm of flow.

Compression ratio: The ratio of discharge pressure to suction pressure at saturated conditions, expressed in absolute terms.

$$CR = \frac{P_d}{P_s}$$

CR is compression ratio;

P_d is saturated discharge pressure, kPa;

P_s is saturated suction pressure, kPa.

Bir kompresör performansı şunlardan etkilenir:

- kompresör hızı
- emme basıncı
- emme sıcaklığı
- tahliye basıncı
- soğutucu akışkan türü

Compressor efficiency

In practice ARI Standard 500-2000 defines the compressor efficiency as the ratio of isentropic work to the actual measured input power.

$$\eta_c = \frac{\dot{m}(h_{2s} - h_1)}{P}$$

The volumetric efficiency

$$\eta_{c,v} = 1 - R \left(\frac{v_1}{v_2} - 1 \right)$$

R : the ratio of the clearance volume to the displacement volume

v_1 and v_2 : the refrigerant specific volumes at the compressor inlet (suction) and exit (discharge)

The refrigeration capacity

$$\dot{Q}_R = \dot{V} \eta_{c,v} \rho_1 (h_1 - h_4)$$

\dot{V} : the compressor volumetric displacement rate (m³/s),

$\eta_{c,v}$: compressor volumetric efficiency

ρ_1 : density of the refrigerant at the compressor inlet (kg/m³)

h_1 and h_4 : specific enthalpies of the refrigerant at compressor inlet and at expansion valve inlet.

Compression ratio, the suction temperature, and lubrication and cooling affect compressor efficiency.

Aşağıdaki çözümler verimi artırmak için:

- *Minimization of temperature lift.* The compressor is most efficient when the condensing pressure is low and the evaporating pressure is high, leading to the minimum temperature lift and compression ratio.
- *Lowering suction temperature.* The lower the suction gas temperature the higher the capacity with no effect on power input. The discharge temperature will also be lower. Suction line insulation is essential.
- *Effective lubrication and cooling.* The compressor must be lubricated and efficiently cooled. Insufficient lubrication increases bearing friction and temperature and reduces compressor efficiency, often resulting in failure.

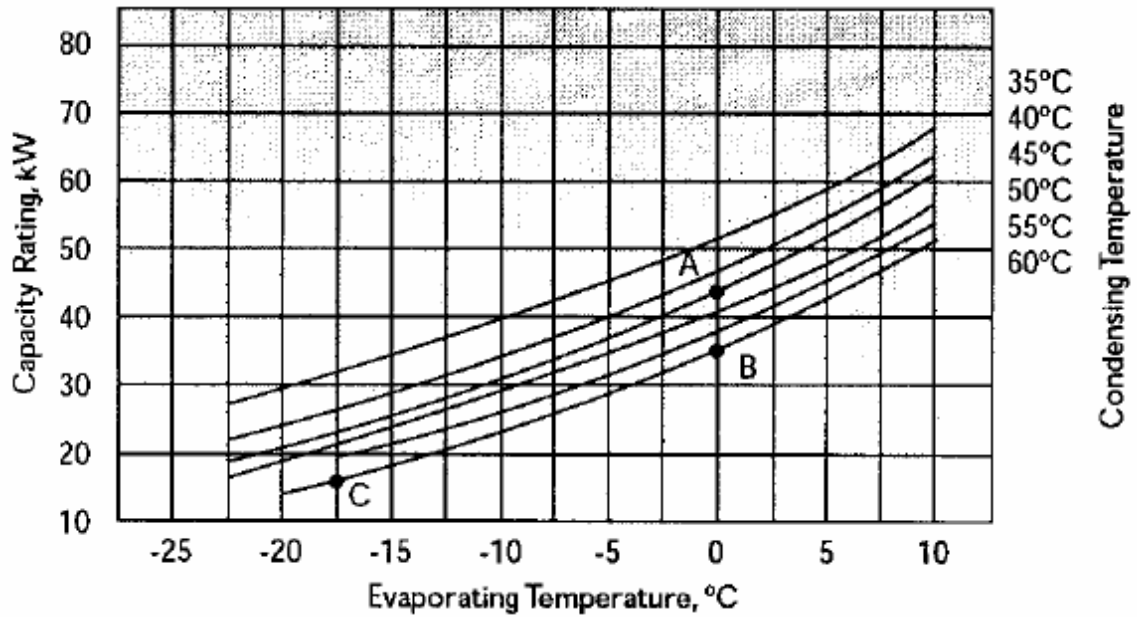
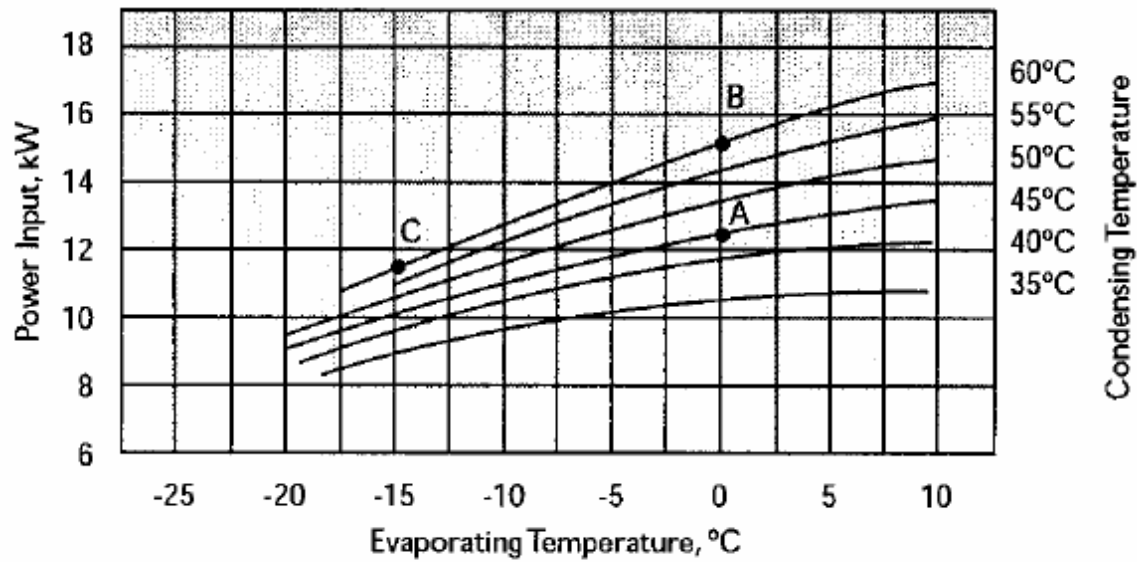

Figure 3.16
Farklı evaporatör ve kondenser sıcaklıklarında kompresör performans profilleri

Compressor capacity control

- A capacity controlled refrigeration unit is a unit in which the compression ability of the compressor can be controlled *to reduce or increase refrigerant mass flow rate*.
- The concept of compressor flow modulation *achieves improved performance in two ways*.
- **First**, by using efficient compressor capacity reduction to prevent the increase in mass flow rate of refrigerant at high ambient temperatures, the COP at higher ambients can be significantly increased.
- **The second** improvement in performance is realized by a change in system sizing strategy.
- The capacity of the unit during cooling can be controlled to achieve proper comfort control.
- One method of system capacity control frequently in use today is hot-gas-bypass.
- **Hot gas-bypass**, where discharge gas from the compressor is vented back to the suction side of the compressor, is an easy retrofit to most systems, but is disastrous from an energy savings viewpoint because capacity is reduced without reducing compressor work, and is probably best avoided.

Diğer olası kapasite kontrol yöntemleri esas olarak üç kategoriye ayrılır :

- *Speed control*. Speed control can be done either continuously or stepwise. Continuously variable speed control is one of the most efficient methods of capacity control, and it offers good control down to about 50% of rated speed of normal compressors.
- *Clearance volume control*. This requires substantial amounts of additional clearance volume to achieve the amount of flow reduction desirable.
- *Valve control*. Suction valve unloading, a compressor capacity control method often used in large air conditioning and refrigeration systems to reduce cooling capacity when load decreases, can achieve some energy savings.

The method is relatively inexpensive.

Two newer methods of compressor flow regulation via valve control are late suction valve closing and early suction valve closing.

Capacity control for varying loads to provide better efficiency

There are several ways to meet varying loads, each with different efficiency, as summarized below

- **Case 1.** Single large compressor. This cannot meet variable load and results in wasted capacity and lower efficiency when at part load.
- **Case 2.** Single large compressor with inbuilt capacity control. This is a good option to meet variable load as long as load stays above 50%.
- **Case 3.** Three small compressors (two with same capacity and one with capacity control). This allows fairly close matching to demand.
- **Case 4.** Three small compressors with different capacities. This is a good option to meet variable load. The aim is to mix and match to varying load with sequence control.
- **Case 5.** Three compressors with parallel control. This is often used, but is not always recommended due to nonlinear input power with capacity turn-down. For example, at 180% capacity (i.e., 3 at 60%), it requires ~240% power due to inefficiencies, which brings an additional input of about 60%.
- **Case 6.** Three compressors (two are on and one is off). In this case, one compressor is used at 100%, and one is used to trim to exact demand (e.g., 80% in the above case), giving 180% capacity with 188% power (22% saving over the above case).

- The load profile must be available to select the best compressor option.
- The efficiency of the different options varies enormously.
- Switching a compressor off to reduce the system capacity is the most efficient method of meeting a reduced load.
- The efficiency of a compressor operating on inbuilt capacity control is always lower than when it operates at full load.
- Any method which recirculates compressed gas back into the suction of a compressor is very poor.
- Compressors are often oversized for an application because so many safety factors are used when calculating the load. This should be minimized as oversized compressors often operate with a lower power factor.
- Regardless of the configuration option selected to meet a load, the control of the compressors is important. The control strategy should be designed to:
 - select the most efficient mix of compressors to meet the load,
 - avoid operation on inbuilt capacity control when possible, and
 - avoid operation at low suction pressures when possible.
- Selecting compressors of different sizes and designing a good control strategy to cycle them to accurately match the most common loads is often the most efficient option.

3.6 Condensers

There are several condensers to be considered when making a selection for installation: air-cooled, water-cooled, shell and tube, shell and coil, tube within a tube, and evaporative condensers.

Each type of condenser has its own unique application.

Selection of condenser type is not easy and depends on the following criteria:

- condenser heat capacity,
- condensing temperature and pressure,
- the flow rates of refrigerant and coolant,
- design temperature for water and/or air,
- operation period,
- climatic conditions.

Condensers utilized in the refrigeration industry are commonly of three types, as follows:

- water-cooled condensers,
- air-cooled condensers,
- evaporative condensers.

Common types of water- and air-cooled refrigerant condensers for commercial refrigeration use are:

- shell and tube, blow-through, horizontal air-flow,
- shell and coil, draw-through, vertical air-flow,
- tube in tube, static or forced air-flow.

The type of condenser selected depends largely on the following considerations:

- size of the cooling load,
- refrigeration used,
- quality and temperature of available cooling water (if any),
- amount of water that can be circulated, if water use is acceptable.

Water-cooled condensers

The most common condensers are generally shell and tube type heat exchangers with refrigerant flow through the shell and water (as coolant) flow through the tubes. These condensers are widely used in large heat capacity refrigerating and chilling applications.

If a water-cooled condenser is used, the following criteria must be examined:

- requirement of cooling water for heat rejection,
- utilization of a cooling tower if inexpensive cooling water is available,
- requirement of auxiliary pumps and piping for recirculating cooling water,
- requirement of water treatment in water recirculation systems,
- space requirements,
- maintenance and service situations, and
- provision of freeze protection substances and tools for winter operation.



Figure 3.17 Various water-cooled condensers

Air-cooled condensers

The air-cooled condensers find applications in domestic, commercial, and industrial refrigerating, chilling, freezing, and air conditioning systems with a common capacity of 20–120 tons.

The advantages of air-cooled condensers are:

- no water requirement,
- standard outdoor installation,
- elimination of freezing, scaling, and corrosion problems,
- elimination of water piping, circulation pumps, and water treatment,
- low installation cost, and
- low maintenance and service requirement.

They have some disadvantages:

- high condensing temperatures,
- high refrigerant cost because of long piping runs,
- high power requirements per kW of cooling,
- high noise intensity, and
- multiple units required for large-capacity systems.

Figure 3.18
A typical air-cooled condenser



Evaporative condensers

- Evaporative condensers are apparently water-cooled designs and work on the principle of cooling by evaporating water into a moving air stream.
- The effectiveness of this evaporative cooling process depends upon the wet bulb temperature of the air entering the unit, the volume of air flow and the efficiency of the air/water interface.
- Evaporative condensers use water sprays and air flow to condense refrigerant vapors inside the tubes.
- The following are some characteristics of these condensers:
 - reduced circulating water for a given capacity,
 - water treatment is necessary,
 - reduced space requirement,
 - small piping sizes and short overall lengths,
 - small system pumps,
 - availability of large capacity units and indoor configurations.

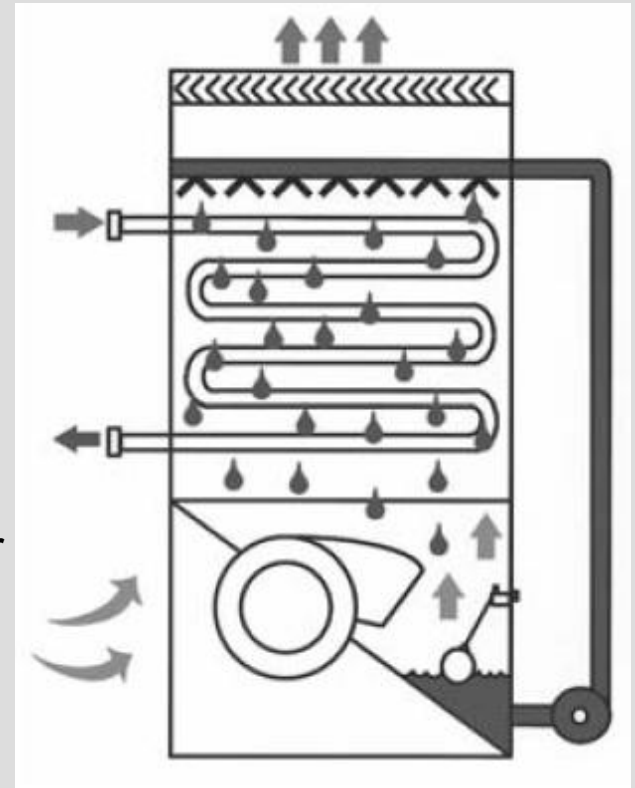

Figure 3.19 An evaporative condenser.

Cooling towers

- Cooling towers are like evaporative condensers, working on the principle of cooling by evaporating water into a moving air stream.
- The effectiveness of this evaporative cooling process depends upon the wet bulb temperature of the air entering the unit, the volume of air flow and the efficiency of the air/water interface.
- Cooling towers are essentially large evaporative coolers where the cooled water is circulated to a remote shell and tube refrigerant condenser.
- Note that the cooling water is circulating through the tubes while refrigerant vapor condenses and gathers in the lower region of the heat exchanger.

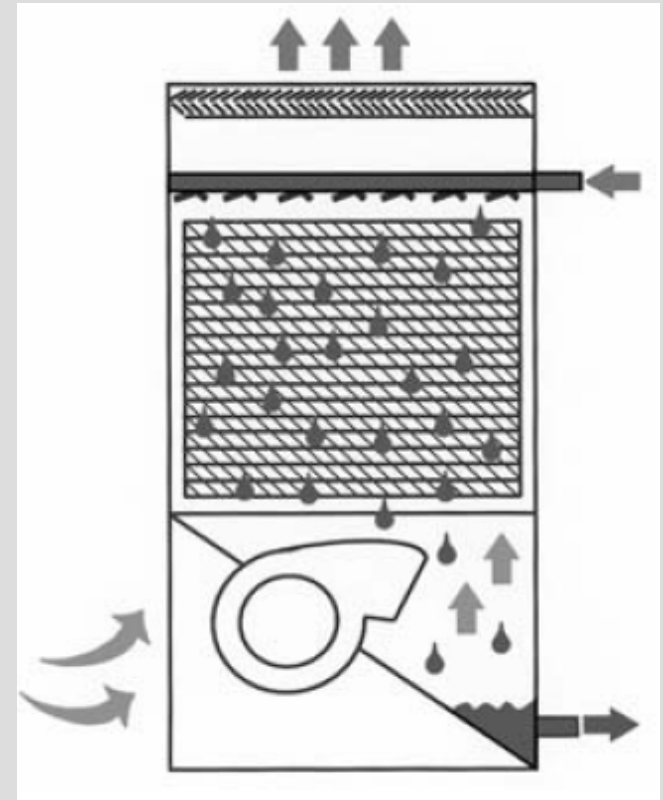
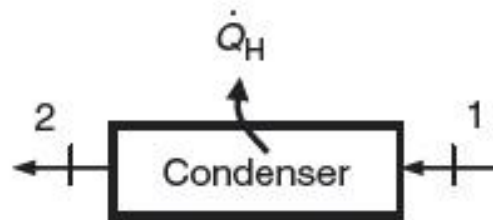

Figure 3.19 A counterflow cooling tower

Energy and Exergy Analysis of Condenser

- Condensers are used to reject heat from a refrigeration system. In a vapor-compression refrigeration cycle, the refrigerant is cooled and condensed as it flows in the condenser coils.

$$\dot{m}_1 = \dot{m}_2$$



(a)

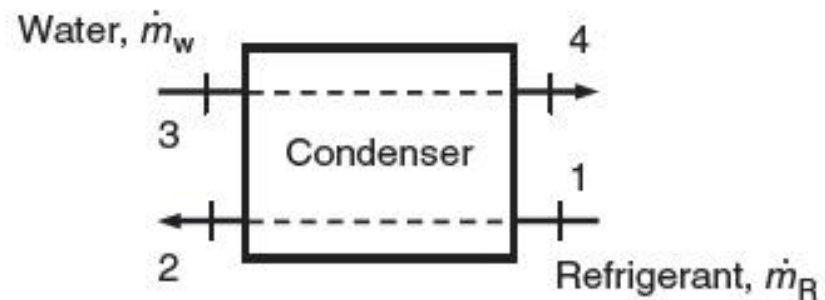

(b)

Figure 3.21 The schematic of condensers considered for mass and energy analysis. (a) Air-cooled condenser. (b) Water-cooled condenser.

The steady-flow energy balance

$$\dot{m} h_1 = \dot{m} h_2 + \dot{Q}_{out}$$

$$\dot{Q}_{out} = \dot{m} (h_1 - h_2)$$

Assuming that heat exchanger is insulated, the energy balance

$$\dot{m}_R h_1 + \dot{m}_w h_3 = \dot{m}_R h_2 + \dot{m}_w h_4$$

$$\dot{m}_R (h_1 - h_2) = \dot{m}_w (h_4 - h_3)$$

The rate of heat rejected to water

$$\dot{Q}_{out} = \dot{m}_R (h_1 - h_2) = \dot{m}_w (h_4 - h_3)$$

$$\dot{S}_{in} - \dot{S}_{out} + \dot{S}_{gen} = \Delta \dot{S}_{sys} = 0$$

$$\dot{S}_{gen} = \dot{S}_{out} - \dot{S}_{in}$$

$$\dot{S}_{gen} = \frac{\dot{Q}_H}{T_H} + \dot{m} s_2 - \dot{m} s_1$$

$$= \dot{m} \left(s_2 - s_1 + \frac{q_H}{T_H} \right)$$

an entropy balance on the condenser

exergy destruction in the condenser

$$\dot{E}x_{dest} = T_0 \dot{S}_{gen} = \dot{m} T_0 \left(s_2 - s_1 + \frac{q_H}{T_H} \right)$$

The exergy destruction can also be determined by writing an exergy balance on the condenser

$$\dot{E}x_{in} - \dot{E}x_{out} - \dot{E}x_{dest} = 0$$

$$\dot{E}x_{dest} = \dot{E}x_{in} - \dot{E}x_{out}$$

$$\dot{E}x_{dest} = \left(\dot{E}x_1 - \dot{E}x_2 \right) - \dot{E}x_{\dot{Q}_H}$$

$$= \dot{m} \left[h_1 - h_2 - T_0 (s_1 - s_2) \right] - \dot{Q}_H \left(1 - \frac{T_0}{T_H} \right)$$

exergy efficiency of the condenser

$$\eta_{ex,Cond} = \frac{\dot{E}x_{\dot{Q}_H}}{\dot{E}x_1 - \dot{E}x_2} = \frac{\dot{Q}_H \left(1 - \frac{T_0}{T_H} \right)}{\dot{m} \left[h_1 - h_2 - T_0 (s_1 - s_2) \right]} = 1 - \frac{\dot{E}x_{dest}}{\dot{E}x_1 - \dot{E}x_2}$$

an entropy balance

$$\dot{S}_{gen} = \dot{S}_{out} - \dot{S}_{in}$$

$$\dot{S}_{gen} = \left(\dot{m}_R s_2 + \dot{m}_w s_4 \right) - \left(\dot{m}_R s_1 + \dot{m}_w s_3 \right)$$

$$= \dot{m}_R (s_2 - s_1) - \dot{m}_w (s_3 - s_4)$$

Example 3.2

Refrigerant-134a enters the condenser of a refrigeration cycle at 800 kPa and 60 °C with a flow rate of 0.095 kg/s and leaves at the same pressure subcooled by 3.3 °C. The refrigerant is condensed by rejecting its heat to water which experiences a temperature rise of 11 °C. Determine (a) the rate of heat rejected in the condenser, (b) the mass flow rate of water, (c) the COP of this refrigeration cycle if the cooling load at these conditions is 12 kW, and (d) the rate of exergy destruction in the condenser. Take $T_0 = 25\text{ °C}$.

Solution

(a) We refer to Figure 3.21b for the schematic of the condenser. The properties of refrigerant at the inlet and exit states of the condenser are (from R134a tables)

$$\left. \begin{array}{l} P_1 = 800 \text{ kPa} \\ T_1 = 60\text{ °C} \end{array} \right\} \begin{array}{l} h_1 = 296.81 \text{ kJ/kg} \\ s_1 = 1.011 \text{ kJ/kg} \cdot \text{K} \end{array}$$

$$\left. \begin{array}{l} P_2 = 800 \text{ kPa} \\ T_2 = T_{\text{sat}} @ 800 \text{ kPa} - \Delta T_{\text{subcool}} = 31.3 - 3.3 = 28\text{ °C} \end{array} \right\} \begin{array}{l} h_2 \cong h_f @ 28\text{ °C} = 90.69 \text{ kJ/kg} \\ s_2 \cong s_f @ 28\text{ °C} = 0.3383 \text{ kJ/kg} \cdot \text{K} \end{array}$$

The rate of heat rejected in the condenser is

$$\dot{Q}_H = \dot{m}_R(h_1 - h_2) = (0.095 \text{ kg/s})(296.81 - 90.69) \text{ kJ/kg} = \mathbf{19.58 \text{ kW}}$$

(b) The mass flow rate of water can be determined from an energy balance on the condenser:

$$\begin{aligned}\dot{Q}_H &= \dot{m}_R(h_1 - h_2) = \dot{m}_w c_p \Delta T_w \\ 19.58 \text{ kW} &= \dot{m}_w (4.18 \text{ kJ/kg} \cdot ^\circ\text{C})(11 ^\circ\text{C}) \\ \dot{m}_w &= \mathbf{0.426 \text{ kg/s}}\end{aligned}$$

The specific heat of water is taken to be $4.18 \text{ kJ/kg} \cdot ^\circ\text{C}$.

(c) From the definition of COP for a refrigerator,

$$\text{COP} = \frac{\dot{Q}_L}{\dot{W}_{\text{in}}} = \frac{\dot{Q}_L}{\dot{Q}_H - \dot{Q}_L} = \frac{12 \text{ kW}}{(19.58 - 12) \text{ kW}} = \mathbf{1.58}$$

(d) The entropy generation and the exergy destruction in the condenser are

$$\begin{aligned}\dot{S}_{\text{gen}} &= \dot{m}_R(s_2 - s_1) + \frac{\dot{Q}_H}{T_H} \\ &= (0.095 \text{ kg/s})(0.3383 - 1.011) \text{ kJ/kg} \cdot \text{K} + \frac{19.58 \text{ kW}}{298 \text{ K}} = 0.001794 \text{ kW/K} \\ \dot{E}x_{\text{dest}} &= T_0 \dot{S}_{\text{gen}} = (298 \text{ K})(0.001794 \text{ kJ/kg} \cdot \text{K}) = \mathbf{0.5345 \text{ kW}}\end{aligned}$$

3.7 Evaporators

- Evaporator can be considered the point of heat capture in a refrigeration system and provides the cooling effect required for any particular application.
- There are almost as many different types of evaporators as there are applications of heat exchangers. However, evaporators are divided into two categories such as
 - **direct cooler evaporators** that cool air that, in turn, cools the product
 - **indirect cooler evaporators** that cool a liquid such as brine solution that, in turn, cools the product.
- In practice, the following evaporators are commonly used for cooling, refrigerating, freezing, and air conditioning applications:
 - **liquid coolers,**
 - **air coolers, and/or gas coolers.**

Liquid coolers

Shell and tube type heat exchangers are the more common form of evaporation units for water cooling and chilling applications.

These are utilized to cool liquids, which can be used as the secondary refrigerant or to cool the final products directly.

In practice, these types of heat exchangers are known as liquid coolers or chillers.

Some example applications in food and refrigeration industry are:

- chilling of drinkable water,
- chilling of water for air conditioning coils,
- chilling of milk after pasteurization, and
- process cooling operations.

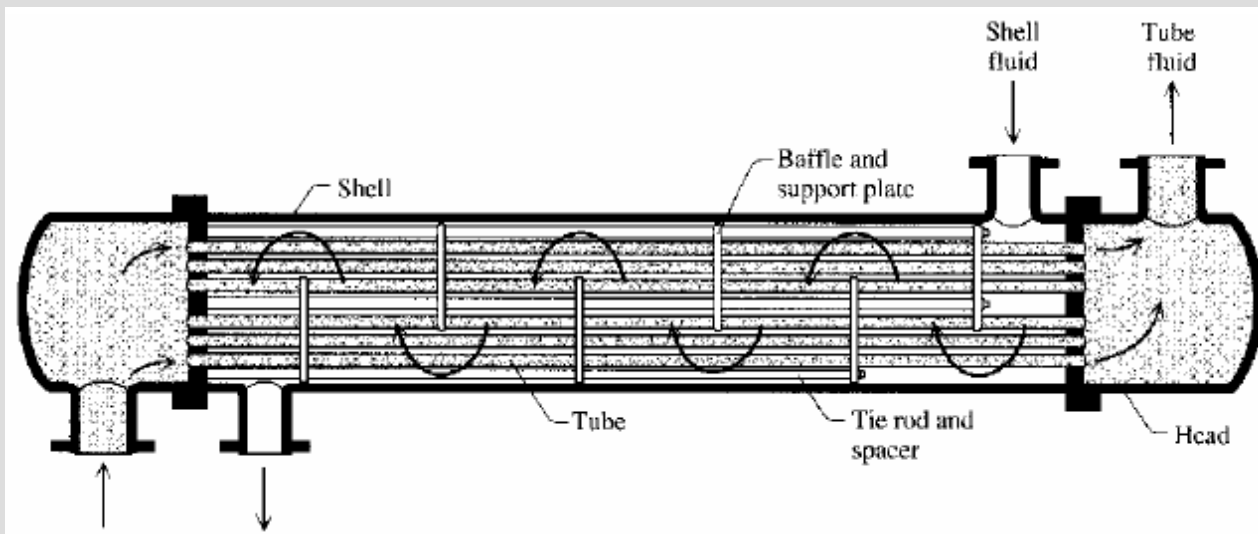

Figure 3.20 A shell-tube type evaporator

- Chilled water systems can use either a flooded evaporator or a direct-expansion evaporator which are typically shell and tube type heat exchangers.
- If the refrigerant vaporizes on the outside surface of the tubes the evaporator is a *flooded cooler*;
- If it vaporizes inside the tubes the evaporator is a *dry cooler*
- In this more common type, the mixture of liquid and vapor is evaporated completely, usually with some degree of superheating.
- In a flooded cooler the water or brine is circulated through the tubes, which are usually finned to provide an increment in the heat transfer rate and a decrease in the evaporator size.
- In a dry cooler the liquid refrigerant is contained within the tubes, and water or brine is circulated through the shell of the cooler, which serves as an evaporator.

Air and gas coolers

- These coolers are generally called *direct expansion coils* and consist of a series of tubes through which refrigerant flows.
- The tubes, which are finned to increase the heat transfer rate, are normally arranged into a number of parallel circuits fed from a single throttling valve.
- These coolers are classified as *flooded* and *dry* types.
- In a *flooded coil*, a float valve is used to maintain the preset level in the coil, keeping the evaporator coil close to full of the liquid refrigerant.
- This full contact of the liquid with the tube walls provides a high heat transfer rate.
- In practice flooded type is not preferable, because it requires large amounts of refrigerant.
- A *dry coil* requires only a small amount of refrigerant and this reduces the cost of the refrigerant charge.

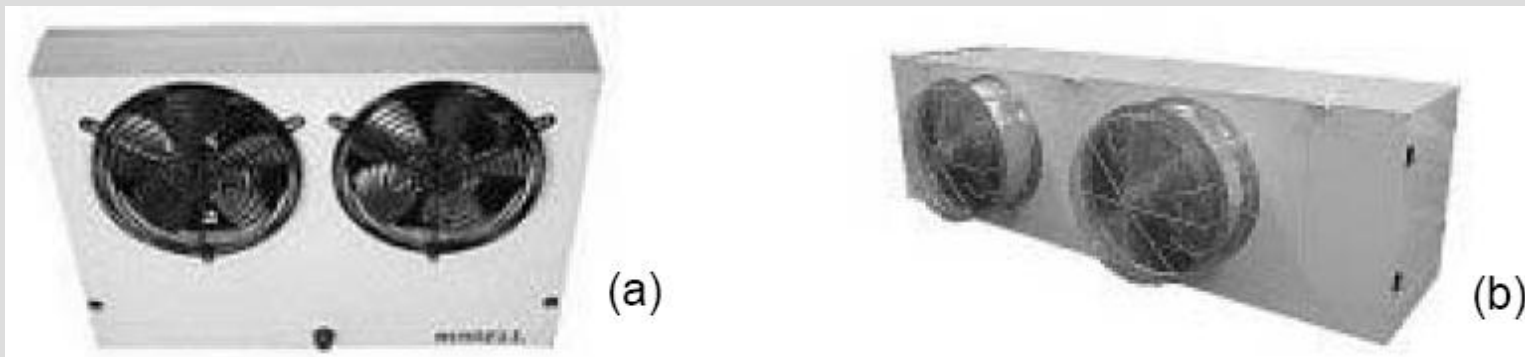
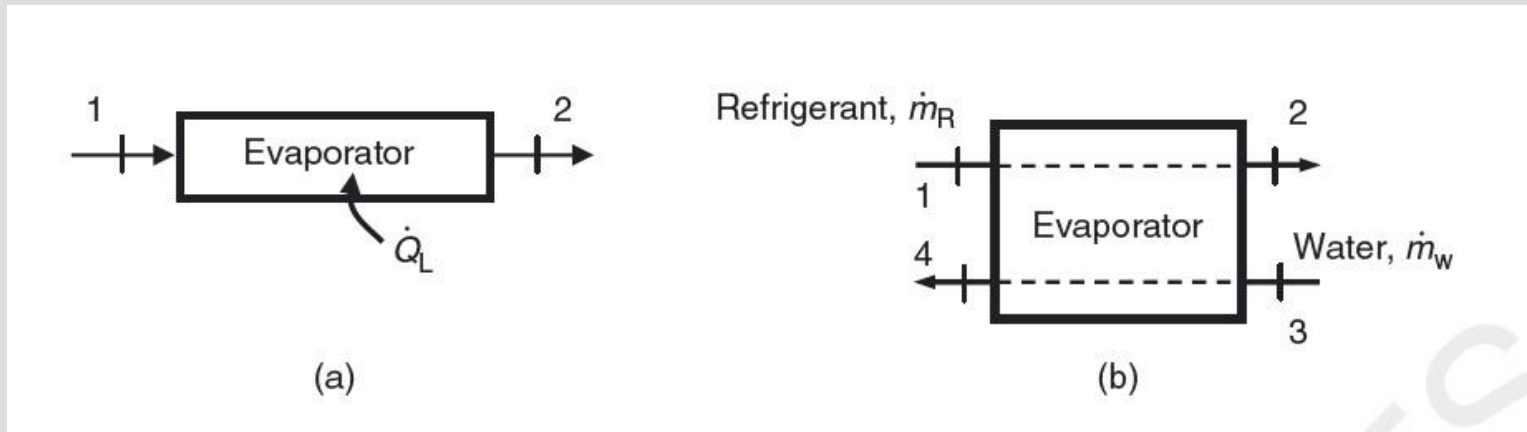

Figure 3.21 Air coolers. (a) Room type. (b) Large-scale industrial type

Energy and Exergy Analysis of Evaporator

- Evaporators are used to absorb heat from the refrigerated space. In a vapor-compression refrigeration cycle, the refrigerant is evaporated as it flows in the evaporator coils.

$$\dot{m}_1 = \dot{m}_2$$



- Figure 3.24** The schematic of evaporators considered for mass and energy analysis. (a) Refrigerant absorbing heat from a space. (b) Refrigerant absorbing heat from water.

Assuming that heat exchanger is insulated, the energy balance in this case becomes.

$$\dot{m}_R h_1 + \dot{m}_w h_3 = \dot{m}_R h_2 + \dot{m}_w h_4$$
$$\dot{m}_R (h_2 - h_1) = \dot{m}_w (h_3 - h_4)$$

The rate of heat absorbed by the refrigerant (and rejected from the water)

$$Q_{in} = \dot{m}_R (h_2 - h_1) = \dot{m}_w (h_3 - h_4)$$

an entropy balance on the evaporator

$$\dot{S}_{in} - \dot{S}_{out} + \dot{S}_{gen} = \Delta \dot{S}_{sys} = 0$$

$$\dot{S}_{gen} = \dot{S}_{out} - \dot{S}_{in}$$

$$\dot{S}_{gen} = \dot{m} s_2 - \dot{m} s_1 - \frac{\dot{Q}_H}{T_H}$$

$$= \dot{m} \left(s_2 - s_1 - \frac{q_L}{T_L} \right)$$

the exergy destruction in the evaporator

$$\dot{E}x_{dest} = T_0 \dot{S}_{gen} = \dot{m} T_0 \left(s_2 - s_1 - \frac{q_L}{T_L} \right)$$

exergy destruction can also be determined by writing an exergy balance on the evaporator:

$$\dot{E}x_{in} - \dot{E}x_{out} - \dot{E}x_{dest} = 0$$

$$\dot{E}x_{dest} = \dot{E}x_{in} - \dot{E}x_{out}$$

$$\dot{E}x_{dest} = -\dot{E}x_{\dot{Q}_L} - \dot{E}x_1 - \dot{E}x_2$$

$$= \left(\dot{E}x_1 - \dot{E}x_2 \right) - \dot{E}x_{\dot{Q}_L}$$

$$= \dot{m} \left[h_1 - h_2 - T_0 (s_1 - s_2) \right] - \left[-\dot{Q}_L \left(1 - \frac{T_0}{T_L} \right) \right]$$

The exergy efficiency of the evaporator

$$\eta_{ex,Evap} = \frac{\dot{E}x_{\dot{Q}_L}}{\dot{E}x_1 - \dot{E}x_2} = \frac{-\dot{Q}_L \left(1 - \frac{T_0}{T_L} \right)}{\dot{m} \left[h_1 - h_2 - T_0 (s_1 - s_2) \right]} = 1 - \frac{\dot{E}x_{dest}}{\dot{E}x_1 - \dot{E}x_2}$$

- If we consider **Figure 3.24b** for the operation of an evaporator, **an entropy balance** may be written as ;

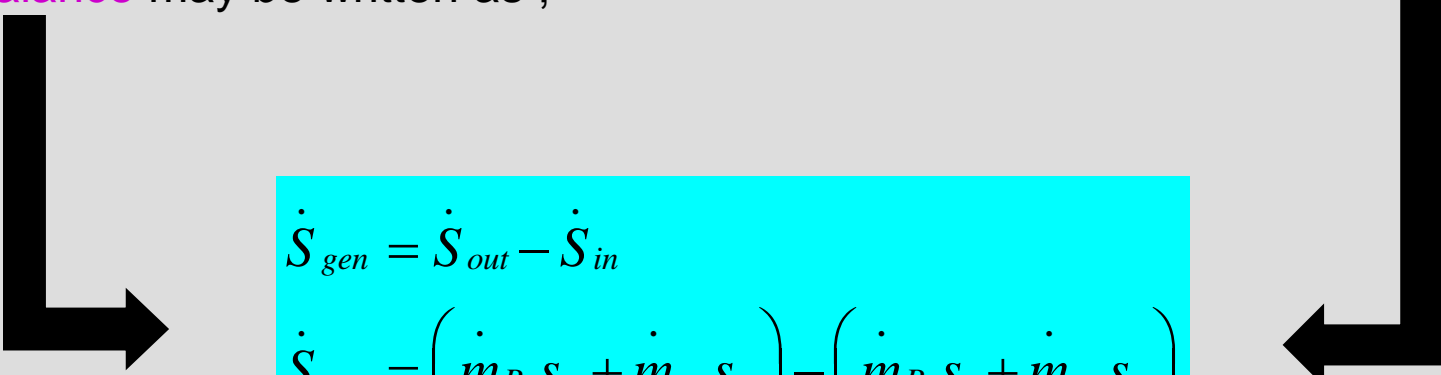
$$\begin{aligned}\dot{S}_{gen} &= \dot{S}_{out} - \dot{S}_{in} \\ \dot{S}_{gen} &= \left(\dot{m}_R s_2 + \dot{m}_w s_4 \right) - \left(\dot{m}_R s_1 + \dot{m}_w s_3 \right) \\ &= \dot{m}_w (s_4 - s_3) - \dot{m}_R (s_1 - s_2)\end{aligned}$$

Then the **exergy destruction in the evaporator** becomes

$$\dot{E}x_{dest} = T_0 \dot{S}_{gen} = T_0 \left[\dot{m}_w (s_4 - s_3) - \dot{m}_R (s_1 - s_2) \right]$$

Example 3.3

Heat is absorbed from a cooled space at 32°F at a rate of 320 Btu/min by refrigerant-22 that enters the evaporator at -12°F with a quality of 0.3 and leaves as saturated vapor at the same pressure. Determine (a) the volume flow rates of R-22 at the evaporator inlet and outlet and (b) the rate of exergy destruction in the evaporator and the exergy efficiency of the evaporator. Take $T_0 = 77^\circ\text{F}$. The properties of R-22 at the inlet and exit of the evaporator are as follows:

$$h_1 = 102.67\text{ Btu/lbm}, s_1 = 0.2776\text{ Btu/lbm} \cdot \text{R}, v_1 = 0.5332\text{ ft}^3/\text{lbm}$$

$$h_2 = 169.82\text{ Btu/lbm}, s_2 = 0.4276\text{ Btu/lbm} \cdot \text{R}, v_2 = 1.750\text{ ft}^3/\text{lbm}$$

Solution

(a) The mass flow rate of R-22 may be determined from an energy balance on the evaporator to be (see Figure 3.24a)

$$\dot{Q}_L = \dot{m}(h_2 - h_1) \longrightarrow 320/60\text{ Btu/s} = \dot{m}(169.82 - 102.67)\text{ Btu/lbm} \longrightarrow \dot{m} = 0.0794\text{ lbm/s}$$

The volume flow rate at the evaporator inlet and outlet are

$$\dot{V}_1 = \dot{m}v_1 = (0.0794\text{ lbm/s})(0.5332\text{ ft}^3/\text{lbm}) = 0.04235\text{ ft}^3/\text{s} = \mathbf{2.54\text{ ft}^3/\text{min}}$$

$$\dot{V}_2 = \dot{m}v_2 = (0.0794\text{ lbm/s})(1.750\text{ ft}^3/\text{lbm}) = 0.139\text{ ft}^3/\text{s} = \mathbf{8.34\text{ ft}^3/\text{min}}$$

(b) The entropy generation and the exergy destruction are

$$\begin{aligned}\dot{S}_{\text{gen}} &= \dot{m}(s_2 - s_1) - \frac{\dot{Q}_L}{T_L} \\ &= (0.0794 \text{ lbm/s})(0.4276 - 0.2776) \text{ Btu/lbm} \cdot \text{R} - \frac{5.33 \text{ Btu/s}}{492 \text{ R}} = 0.001073 \text{ Btu/s} \cdot \text{R}\end{aligned}$$

$$\dot{E}x_{\text{dest}} = T_0 \dot{S}_{\text{gen}} = (537 \text{ R})(0.001073 \text{ Btu/s} \cdot \text{R}) = \mathbf{0.576 \text{ Btu/s}}$$

The exergy decrease of the refrigerant as it flows in the evaporator is

$$\begin{aligned}\dot{E}x_1 - \dot{E}x_2 &= \dot{m}(h_1 - h_2) - \dot{m}T_0(s_1 - s_2) \\ &= 5.33 - (0.0794 \text{ lbm/s})(537 \text{ R})(0.2776 - 0.4276) \text{ Btu/lbm} \cdot \text{R} \\ &= 1.06 \text{ Btu/s}\end{aligned}$$

The exergy efficiency is then

$$\eta_{\text{ex,Evap}} = 1 - \frac{\dot{E}x_{\text{dest}}}{\dot{E}x_1 - \dot{E}x_2} = 1 - \frac{0.576}{1.06} = 0.458 = \mathbf{45.8\%}$$

3.8 Throttling Devices

- In practice, throttling devices, called either *expansion valves* or *throttling valves*, are used to reduce the refrigerant condensing pressure (high pressure) to the evaporating pressure (low pressure) by a throttling operation and regulate the liquid-refrigerant flow to the evaporator to match the equipment and load characteristics.
- The most common throttling devices are as follows:
 - *thermostatic expansion valves*,
 - *constant pressure expansion valves*,
 - *float valves*, and
 - *capillary tubes*.
- A practical refrigeration system may consist of a large range of mechanical and electronic expansion valves and other flow control devices for small- and large-scale refrigeration systems, comprising *thermostatic expansion valves*, *solenoid valves*, *thermostats* and *pressostats*, *modulating pressure regulators*, *filter driers*, *liquid indicators*, *non-return valves* and *water valves*, and furthermore, *decentralized electronic systems* for full regulation and control.

Thermostatic expansion valves

- The thermostatic expansion valves are essentially reducing valves between the high-pressure side and the low-pressure side of the system.
- These valves, which are the most widely used devices, automatically control the liquid-refrigerant flow to the evaporator at a rate that matches the system capacity to the actual load.
- They operate by sensing the temperature of the superheated refrigerant vapor leaving the evaporator.
- For a given valve type and refrigerant, the associated orifice assembly is suitable for all versions of the valve body and in all evaporating temperature ranges.

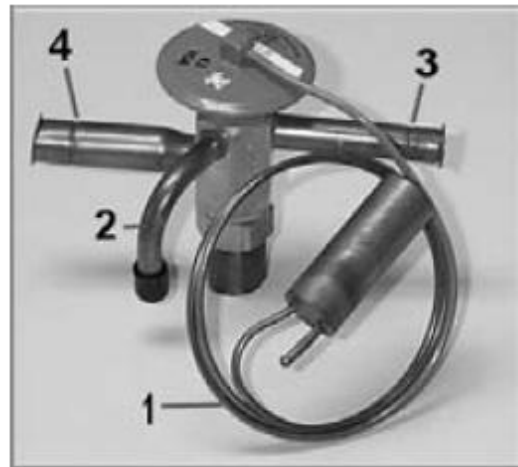

1. Temperature sensor
2. External equalizer
3. From condenser
4. To coil

Figure 3.22
An electronic
expansion valve

Constant pressure expansion valves

- The constant pressure valve is the forerunner of the thermostatic expansion valve.
- It is called an automatic expansion valve due to the fact that it opens and closes automatically without the aid of any external mechanical device.
- These expansion valves are basically pressure regulating devices.
- These valves maintain a constant pressure at outlet.
- They sense and keep the evaporated pressure at a constant value by controlling the liquid-refrigerant flow into the evaporator, based on the suction pressure.
- Refrigerant flows at a rate that exactly matches compressor capacity.
- Their applications are limited because of the constant cooling load.

Float valves

- These valves are divided into high-side float valves and low-side float valves.
- They are employed to control the refrigerant flow to a flooded-type liquid cooler.
- A high-side float valve is located on the high-pressure side of the throttling device.
- It is used in a refrigeration system with a single evaporator, compressor, and condenser.
- A low-side float valve is particularly located on the low-pressure side of the throttling device and may be used in refrigeration systems with multiple evaporators.
- In some cases a float valve operates an electrical switch controlling a solenoid valve which periodically admits the liquid refrigerant to the evaporator, allowing the liquid level to fluctuate within preset limits.

Capillary tubes

- The capillary tube is the simplest type of refrigerant flow control device and may be used in place of an expansion valve.
- The capillary tubes are small-diameter tubes through which the refrigerant flows into the evaporator.
- These devices, which are widely used in small hermetic-type refrigeration systems (up to 30 kW capacity), reduce the condensing pressure to the evaporating pressure in a copper tube of small internal diameter (0.4–3 mm diameter and 1.5–5 m long), maintaining a constant evaporating pressure independently of the refrigeration load change.
- These tubes are used to transmit pressure from the sensing bulb of some temperature control device to the operating element.
- A capillary tube may also be constructed as a part of a heat exchanger, particularly in household refrigerators.
- With capillary tubes, the length of the tube is adjusted to match the compressor capacity.
- Other considerations in determining capillary tube size include condenser efficiency and evaporator size.
- Capillary tubes are most effective when used in small capacity systems.

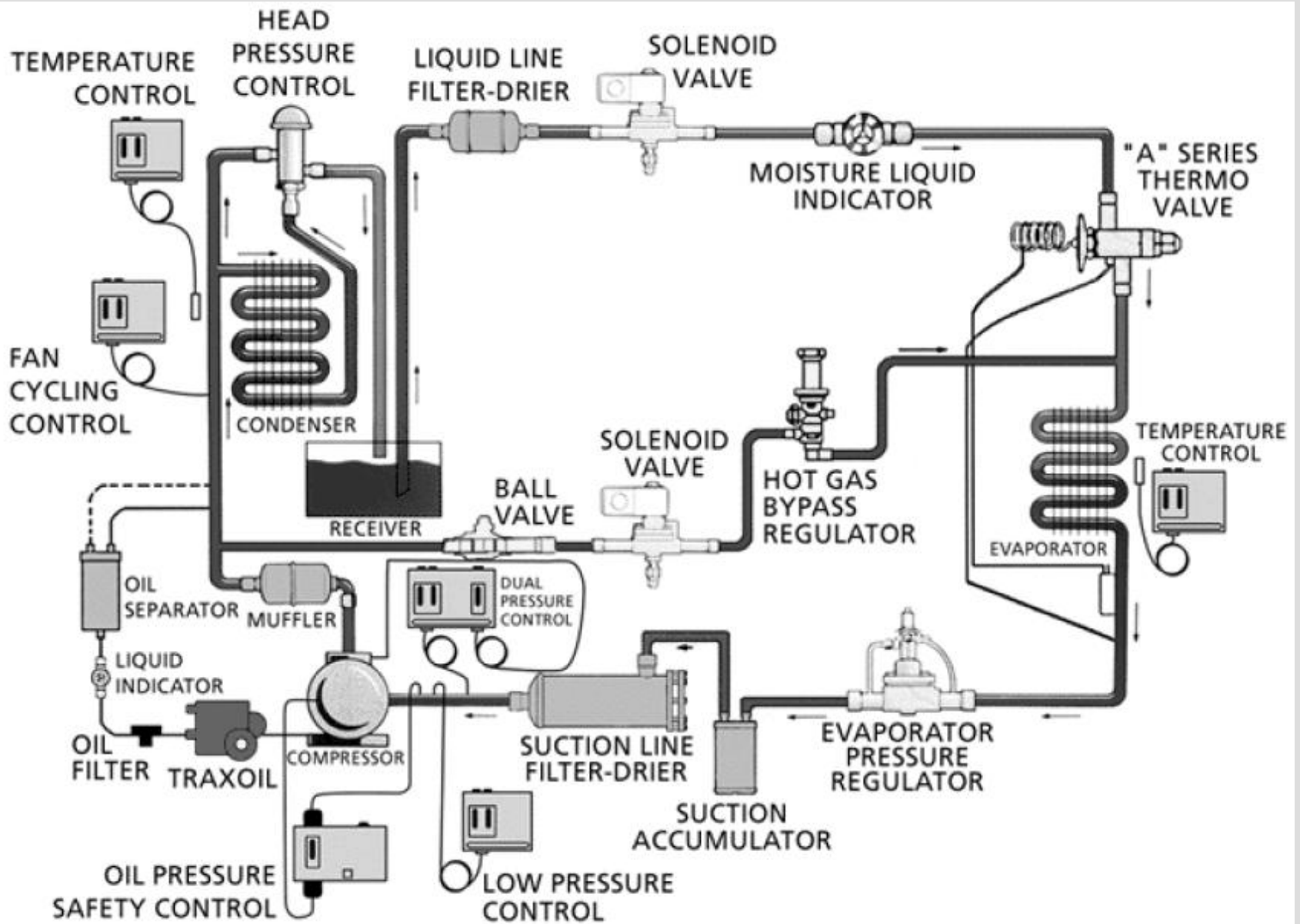

Figure 3.23 A practical vapor compression refrigeration system with all control devices

- *Energy and Exergy Analysis of Throttling Device*

Throttling devices are used to decrease pressure of a fluid. In a vapor-compression refrigeration cycle, the refrigerant enters the throttling valve as a liquid and leaves as a saturated liquid–vapor mixture (Figure 3.27). The conservation of mass principle requires that

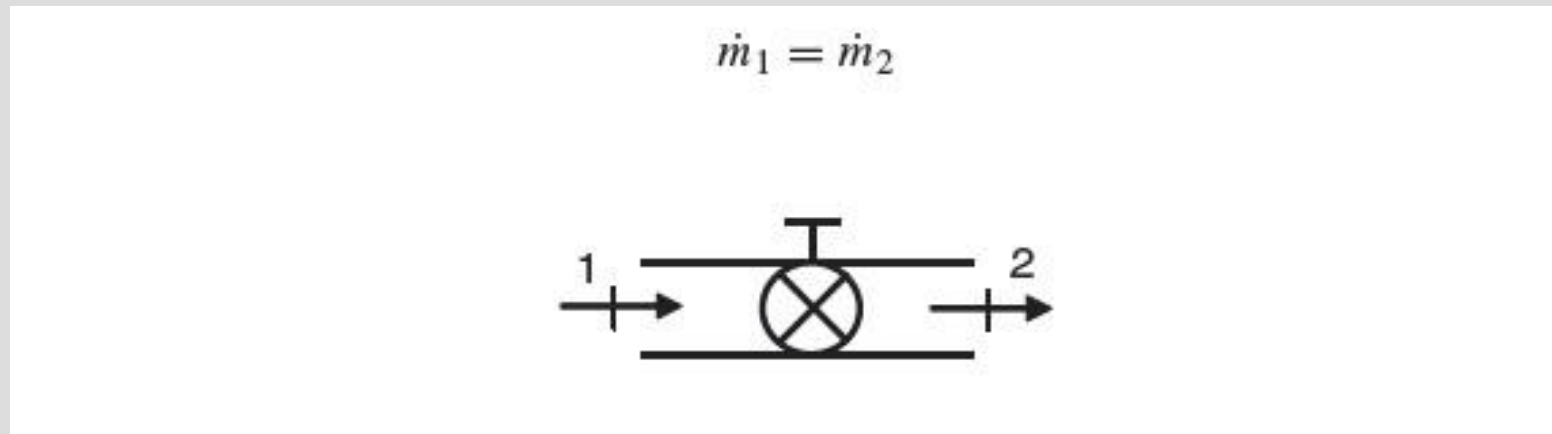

Figure 3.27 The schematic of a throttling valve considered for mass and energy analysis.

- Then the steady-flow energy balance

$$\dot{m} h_1 = \dot{m} h_2 \quad \longrightarrow \quad h_1 = h_2$$

enthalpy

$$h_1 = h_2 \quad \longrightarrow \quad u_1 + P_1 v_1 = u_2 + P_2 v_2$$

an entropy balance on the throttling valve



$$\begin{aligned} \dot{S}_{in} - \dot{S}_{out} + \dot{S}_{gen} &= \Delta \dot{S}_{sys} = 0 \\ \dot{S}_{gen} &= \dot{S}_{out} - \dot{S}_{in} \\ \dot{S}_{gen} &= \dot{m} s_2 - \dot{m} s_1 \\ &= \dot{m} (s_2 - s_1) \end{aligned}$$

The exergy destruction in the throttling valve



$$\dot{Ex}_{dest} = T_0 \dot{S}_{gen} = \dot{m} T_0 (s_2 - s_1)$$

The exergy destruction can also be determined by writing an exergy balance on the condenser:



$$\begin{aligned}\dot{E}x_{in} - \dot{E}x_{out} - \dot{E}x_{dest} &= 0 \\ \dot{E}x_{dest} &= \dot{E}x_{in} - \dot{E}x_{out} \\ \dot{E}x_{dest} &= \dot{E}x_1 - \dot{E}x_2 \\ &= \dot{m} [h_1 - h_2 - T_0 (s_1 - s_2)]\end{aligned}$$

The exergy efficiency of the throttling valve



$$\eta_{ex,Evap} = \frac{0}{\dot{E}x_1 - \dot{E}x_2} = 1 - \frac{\dot{E}x_{dest}}{\dot{E}x_1 - \dot{E}x_2} = 1 - \frac{\dot{E}x_1 - \dot{E}x_2}{\dot{E}x_1 - \dot{E}x_2}$$

Note that there is **no exergy recovered in an expansion valve**, and thus the **exergy efficiency is zero**.

Example 3.4

Refrigerant-134a enters the throttling valve of a heat pump system at 800 kPa as a saturated liquid and leaves at 140 kPa. Determine (a) the temperature of R-134a at the outlet of the throttling valve and (b) the entropy generation and the exergy destruction during this process. Take $T_0 = 25^\circ\text{C}$.

Solution

- (a) The properties of refrigerant at the inlet and exit states of the throttling valve are (from Tables 3–5)

$$\left. \begin{array}{l} P_1 = 800 \text{ kPa} \\ x_1 = 0 \end{array} \right\} \begin{array}{l} h_1 = 95.47 \text{ kJ/kg} \\ s_1 = 0.35404 \text{ kJ/kg} \cdot \text{K} \end{array}$$

$$\left. \begin{array}{l} P_2 = 140 \text{ kPa} \\ h_2 = h_1 = 95.447 \text{ kJ/kg} \end{array} \right\} \begin{array}{l} T_2 = -18.8^\circ\text{C} \\ s_2 = 0.3797 \text{ kJ/kg} \cdot \text{K} \end{array}$$

- (b) Noting that the throttling valve is adiabatic, the entropy generation is determined from

$$s_{\text{gen}} = s_2 - s_1 = (0.3797 - 0.35404) \text{ kJ/kg} \cdot \text{K} = \mathbf{0.0257 \text{ kJ/kg} \cdot \text{K}}$$

Then the irreversibility (i.e., exergy destruction) of the process becomes

$$ex_{\text{dest}} = T_0 s_{\text{gen}} = (298 \text{ K})(0.0257 \text{ kJ/kg} \cdot \text{K}) = \mathbf{7.65 \text{ kJ/kg}}$$

3.9 Auxiliary Devices

Accumulators

- It is well known that compressors are designed to compress vapors, not liquids.
- Many refrigeration systems are subject to the return of excessive quantities of liquid refrigerant to the compressor.
- Liquid refrigerant returning to the compressor dilutes the oil, washes out the bearings, and in some cases causes complete loss of oil in the compressor crankcase.
- This condition is known as oil pumping or slugging and results in broken valve reeds, pistons, rods, crankshafts, and the like.
- The purpose of the accumulator is to act as a reservoir to temporarily hold the excess oil-refrigerant mixture and to return it at a rate that the compressor can safely handle.
- Some accumulators include a heat-exchanger coil to aid in boiling off the liquid refrigerant while subcooling the refrigerant in the liquid line, thus helping the system to operate more efficiently.

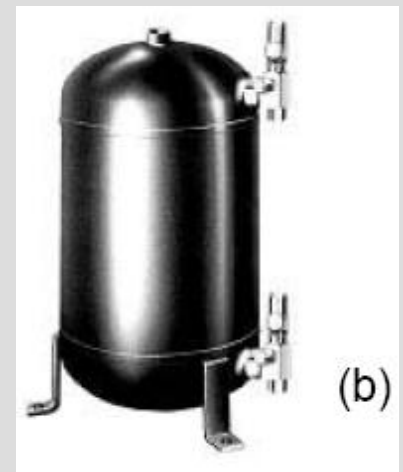

Figure 3.24 An accumulator

Receivers

- If the condenser does not have sufficient space to accommodate the entire refrigerant charge of the system, a receiver tank should be provided.
- The amount of refrigerant required for proper operation of the system determines whether or not a receiver is required.
- In practice, when proper unit operation requires approximately 3.6 kg or more of refrigerant, the use of a receiver is essential.
- Receivers are required on refrigeration systems which use an expansion valve for refrigerant control.
- The receiver provides a place to store the excess refrigerant in the system when the expansion valve restricts the flow to the evaporator.
- Receivers are not required, however, when using a capillary metering system.

Figure 3.25
Receivers. (a)
Horizontal design. (b)
Vertical design.



Oil separators

- Oil separators provide oil separation and limit oil carry-over to approximately 0.0003–0.001% of the total amount of refrigerant, depending on various system characteristics, e.g. operating conditions, refrigerant, start/stop and load/unload frequency, etc.
- These separators are normally used for a large variety of refrigerants, e.g. ammonia, R-134a and propane.
- Note that all the separators require the mounting of an external float assembly to control return from the separator to the compressor.

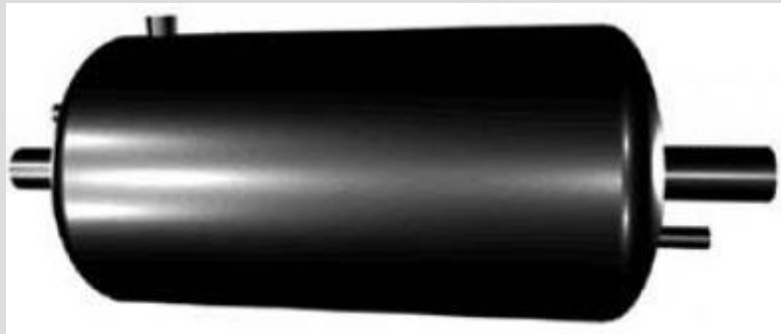

Figure 3.26 A coalescing oil separator

Strainers

- Strainers remove foreign matter such as dirt and metal chips from the refrigerant lines.
- If left in the system, unwanted matter could clog the small orifices of the flow-control devices and check valves and also enter the compressor.
- Various types are available such as straight-through sealed type, cleanable angle type, and the cleanable Y type.

Driers

- In refrigeration systems, moisture is the single most detrimental factor in a refrigeration system.
- A unit can stand only a very small amount of moisture. For this reason, the majority of both field- and factory-assembled refrigeration systems are equipped with driers.
- Some factors influence the selection of the correct size of drier are
 - type and amount of refrigerant,
 - refrigeration system tonnage,
 - line size, and
 - allowable pressure drop.
- When the refrigerant type, line size, and equipment application are known, the drier is generally selected on the basis of recommended capacities, which take into account both drying and refrigerant flow capacity.

Check valves

- Check valves are used for two essential goals:
 - to cause the refrigerant to flow through the flow-control device and
 - to allow the refrigerant to bypass the flow-control device.
- These valves are installed in a loop that bypasses the flow-control device and only open when pressure is exerted in the right direction.
- In operation, the refrigerant pushes either against the valve seat to close it tighter or against its face to cause it to open and allow refrigerant to pass through.
- These valves are usually spring loaded and will open when the pressure difference on the seat reaches about 100 to 135 kPa.

Solenoid valves

- Solenoid valves are extensively used in all types of refrigeration applications.
- These valves are employed as electrically operated line stop valves and perform in the same manner as hand shut-off valves.
- These valves are convenient for remote applications due to the fact that these are electrically operated and controlled easily.

Defrost controllers

A defrost controller with timer operates various control valves and fan relays to quickly and efficiently remove frost and ice accumulation from evaporator surfaces.

There are four easy-to-set defrost steps:

- pump out,
- hot gas,
- equalize, and
- fan delay.

This controller uses reliable, solid-state electronics with a precision quartz time clock and time interval adjusting slide knobs to sequentially operate through the four steps for smooth defrosting.



Figure 3.27 A defrost controller with timer

SOĞUTMA SİSTEMİ ANA ELEMANLARI

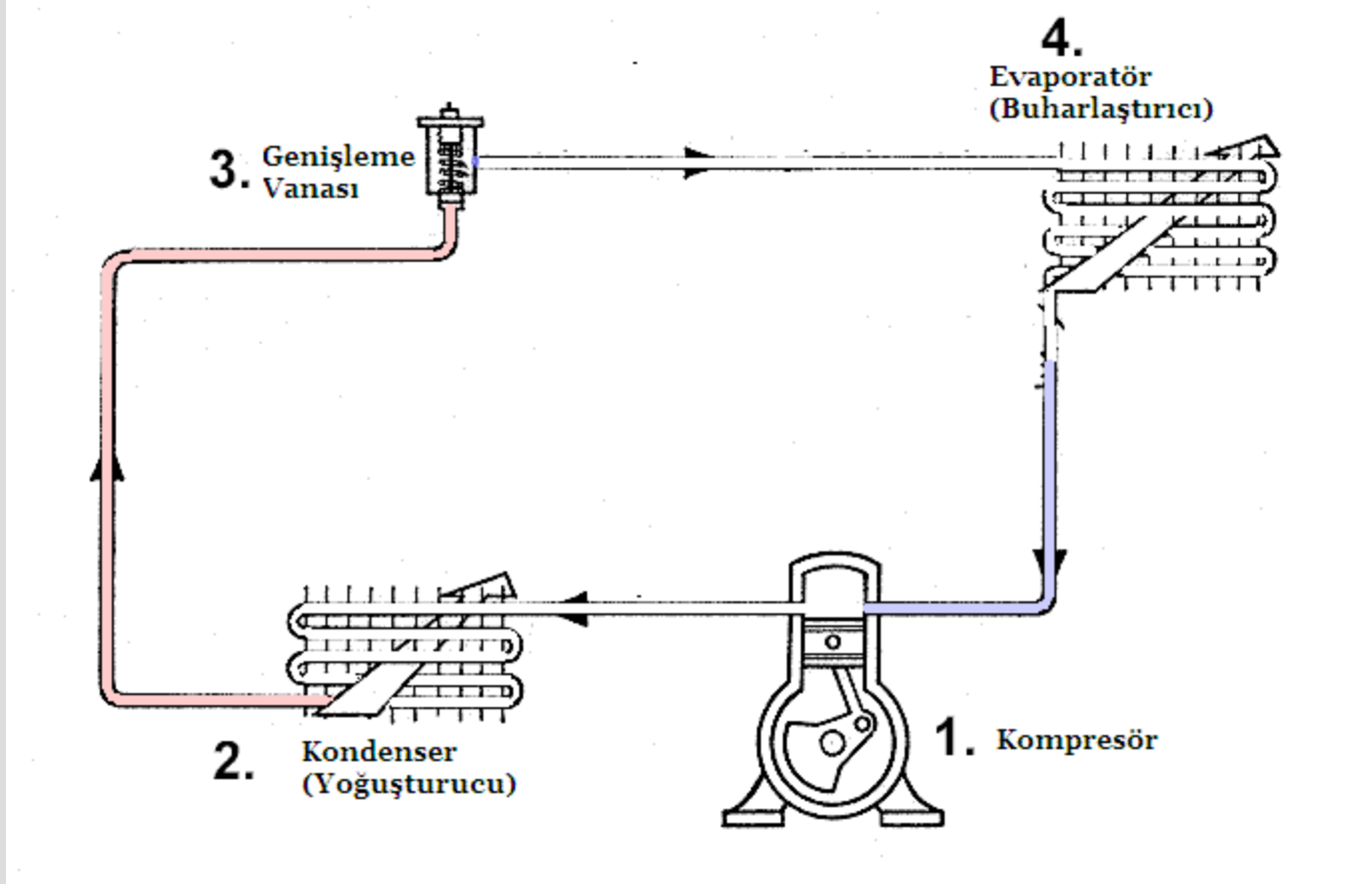

KOMPRESÖRLER

Kompresörler soğutma sisteminin kalbi olarak ele alınabilir.

Soğutucu akışkanın çevrim boyunca dolaştırılarak soğuk kaynaktan sıcak kaynağa ısı iletimi kompresörler yardımı ile meydana gelmektedir.

Yani kompresörler , soğutma devrelerinde buharlaştırıcıda bulunan alçak basınçta buhar halindeki soğutucu akışkanı emerek daha yüksek basınçta olan yoğuşturucuya gönderen iş yutan makinelerdir.

İdeal bir kompresörde şu özellikler aranır:

- İlk harekette dönme momentinin mümkün olduğunca az olması
- Değişik çalışma şartlarında emniyet ve güvenliği muhafaza etmesi,
- Ömrünün uzun olması ve daha az çalışması,
- Titreşim ve gürültü seviyelerinin kısmi ve tam yüklerde ve değişik şartlarda belirli seviyenin üstüne çıkması,
- Daha az güç harcayarak birim soğutma değerini sağlayabilmesi,
- Maliyetin mümkün olduğunca az olması,
- Verimlerinin kısmi yüklerde de düşmemesi

Yapısına Göre Kompresörler

3.1.1. Rotarlı Tip Kompresörler:

Küçük soğutma sistemlerinde kullanılan bu kompresör, bir silindir içerisinde kaçık eksenli olarak dönen bir pistondan ibarettir. Supab tertibatı yoktur. Hacim sıkıştırmalı kompresörlerdir. Ev tipi buzdolaplarında, derin dondurucu ve split ve pencere tipi klimalarda, ve otomobil klimalarında kullanılırlar. Kanatlı tipler, bıçaklı tipe göre daha yüksek kapasiteler için uygundur. 4-450 kW arası üretilirler. Kanat sayısı 4-16 değişir.

Bıçaklı ve kanatlı olmak üzere iki tipte imal edilirler.

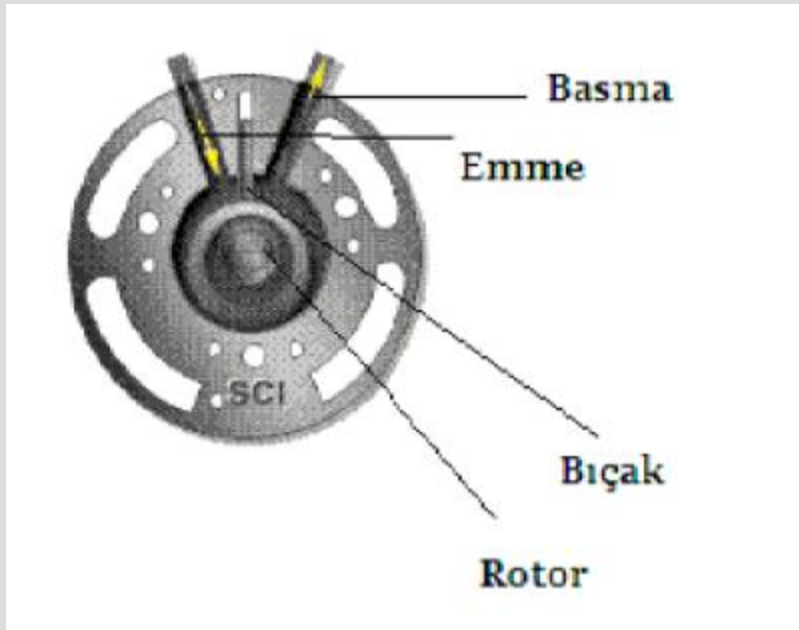

Şekil 3.1 Bıçaklı tip rotorlu tip kompresör

Paletli tip rotorlu kompresör

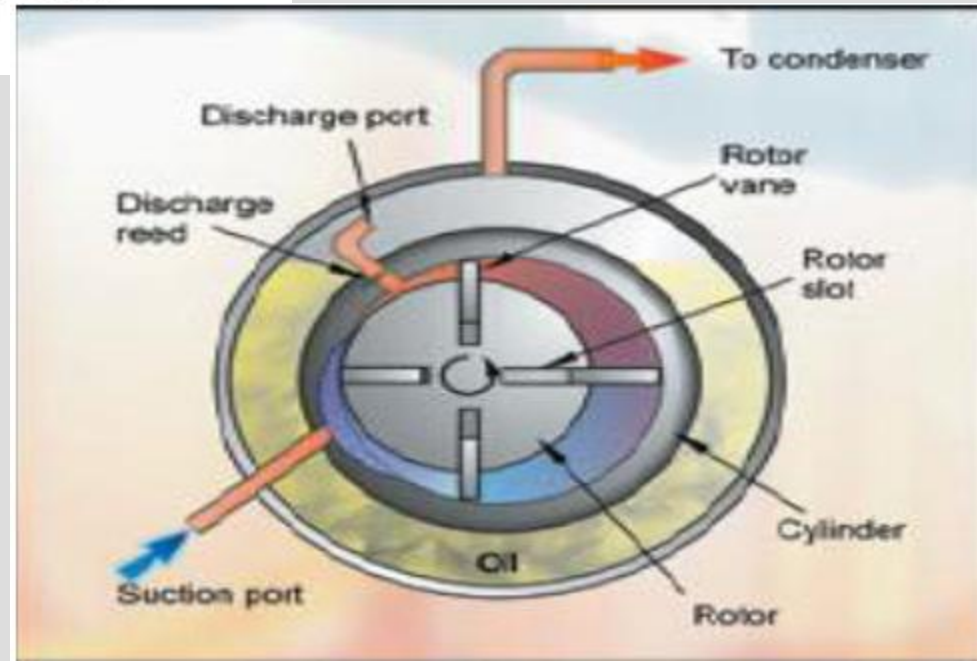
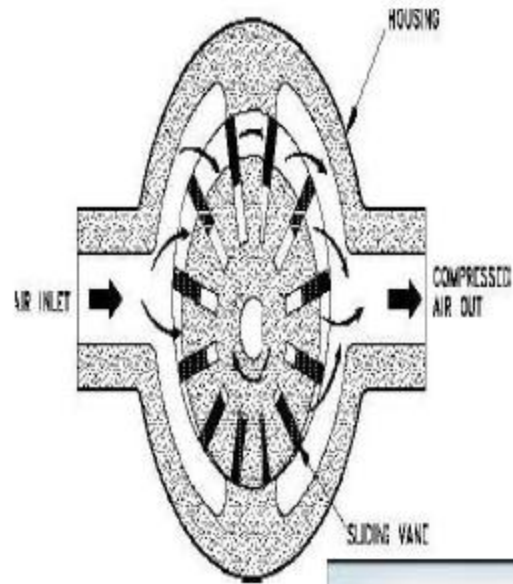
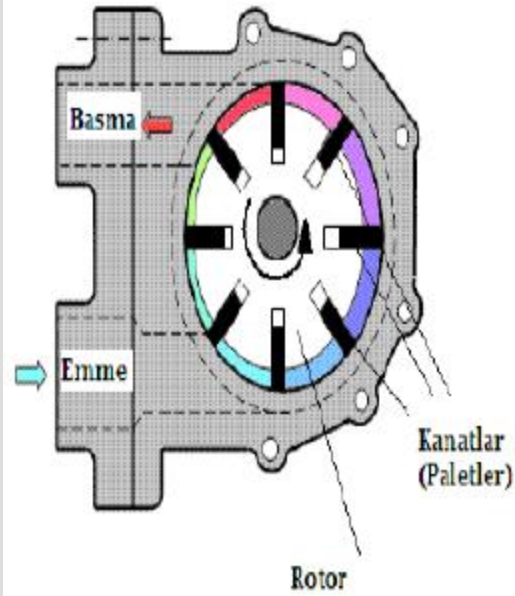

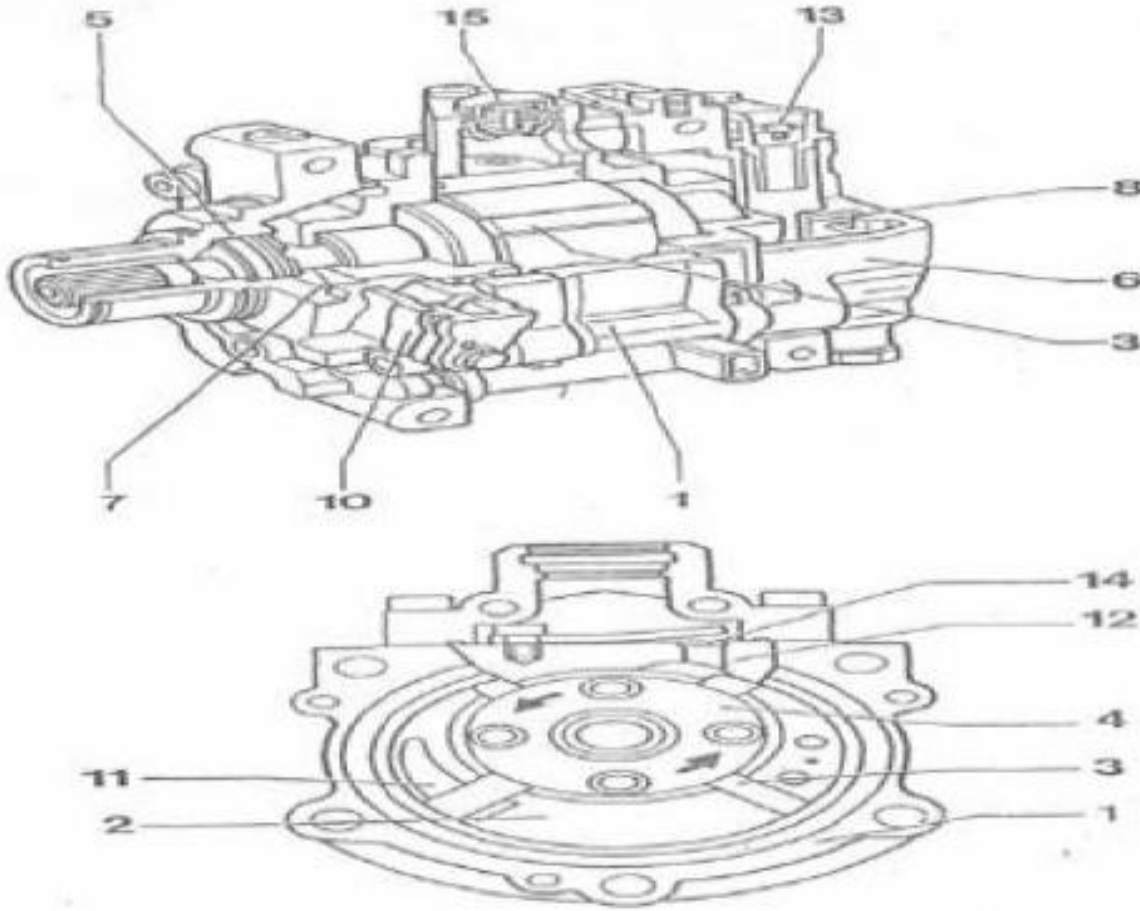

1-Gövde 2-Odacık 3-Palet 4-Göbek 5-Ön kapak 6-Arka kapak 7-Düşük basınç odacığı 8-Yüksek basınç odacığı 9-Ön kapak giriş yeri 10- Kanal 11- Kanal çıkışı 12-Vida 13- Valf 14- Termal kontak

Pistonlu Tip Kompresör

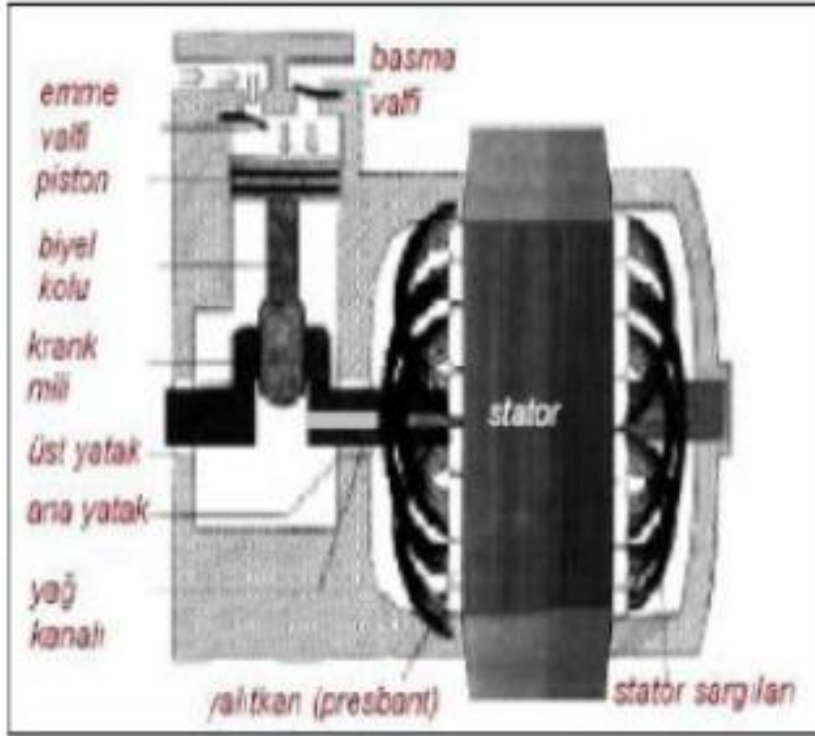

Pistonlu kompresörler özellikle buhar yoğunluğu ve yoğunlaşma basıncı yüksek olan soğutucu akışkanlar için kullanılır.

Örneğin R-22, R-407c, R-134a.

Bir silindir içerisine gidip , gelme hareketi yapan bir pistonla sıkıştırma işlemi yapan bu tip kompresörlerde , tahrik motorunun dönme hareketi bir

krank- biyel sistemi ile doğrusal harekete çevrilir. Bu tip

kompresörlerde , buhar haldeki soğutucu akışkanı çekmek için silindir içerisindeki pistonun aşağı doğru hareketi ile birlikte emiş vanaları açılır.

Buhar haldeki soğutucu akışkan pistonun yukarı doğru hareketiyle sıkıştırılır ve silindir içindeki basınç, yoğunlaşma basıncının biraz üzerine çıktığında akışkan dışarı atılır.

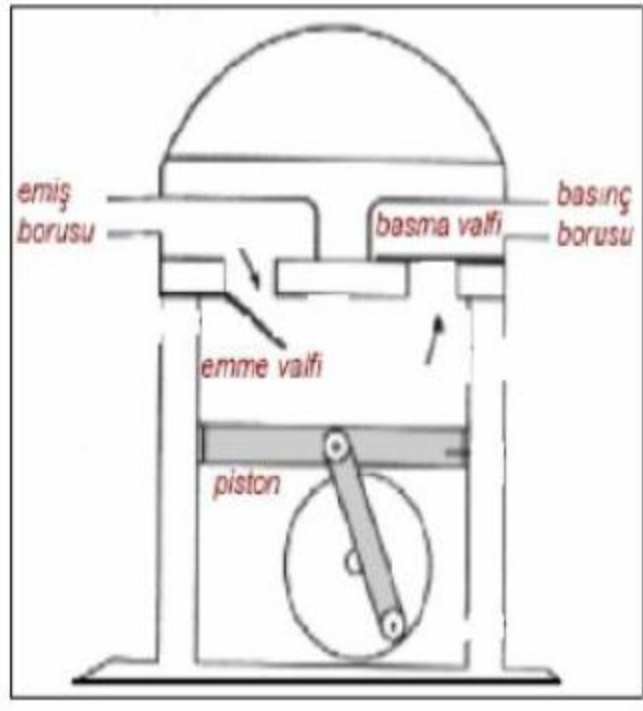

Pistonlu kompresörlerin avantajları:

Pistonlu kompresörler her çeşit motorla tahrik olabilirler.

Devir sayısı kayış kasnak ve benzeri sistemlere ayarlanabilir.

Motor üzerinden kısa devre olarak soğutma deresinde kirlenme olmaz

Tahrik motoru arıza yapınca hemen değiştirilerek, çalışma aksatılmaz.

İmalat kalitesi çok iyidir .

Dezavantajları :

Soğutma devresinde , motorun ısı kayıpları geri kazanılmaz . Isı pompaları açısından önemli bir faktör olduğu unutulmamalıdır.

Sıvı darbelerine karşı diğer kompresörlere nazaran daha az mukavimdir.

Soğutucu akışkan kaçaqları meydana gelir ve bu çok önemli bir mahzurdur

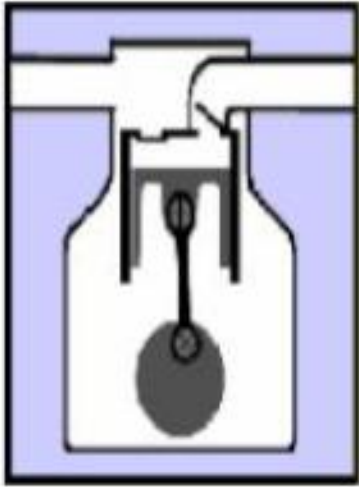

Vidalı (Helisel) Kompresörler

Vidalı kompresörlerde, dişleri birbirini saran iki sonsuz vidadan bir tanesi diğerini hareket ettirerek gazı sıkıştırır. Emme deliği açıkken rotorların dönmesi ile gaz emilir ve emilen gaz vidalar arasındaki gittikçe daralan boşluğu, rotor boyunca doldurduktan sonra emme deliği kapatılır. Rotorlar dönmeye devam ederek aradaki gazı sıkıştırır.

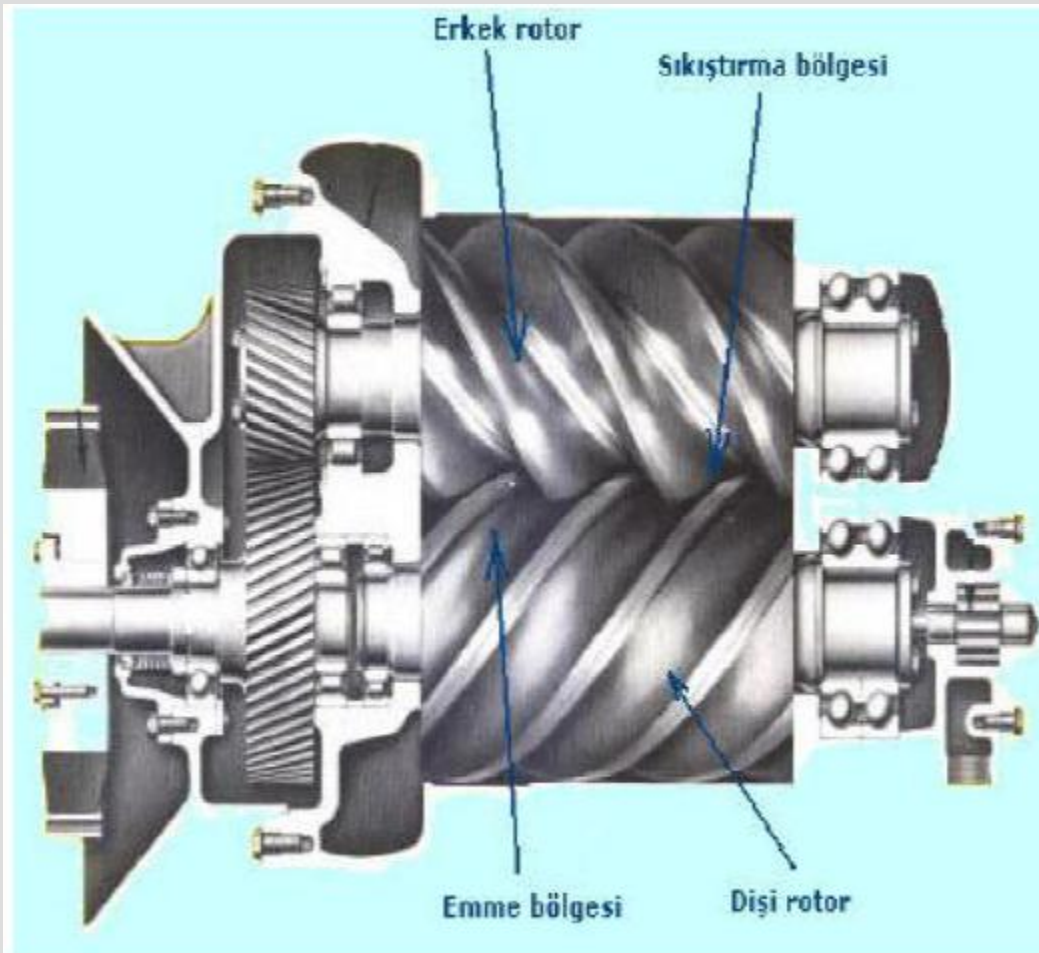

Çalışma prensipleri çok basit olduğundan vidalı kompresörlerin tamir ve bakımı kolaydır, ömürleri uzundur. Diğer kompresör tiplerine göre daha az yer kaplar, daha az titreşim yapar, kayış kasnak olmadan tahrik sistemine bağlanırlar. Hareket eden parçaların sayısı az olduğundan mekanik verimleri dolayısıyla toplam verimleri yüksektir. Chiller gruplarında ve Özellikle uçak kabinlerinin iklimlendirilmesi için kullanılır.

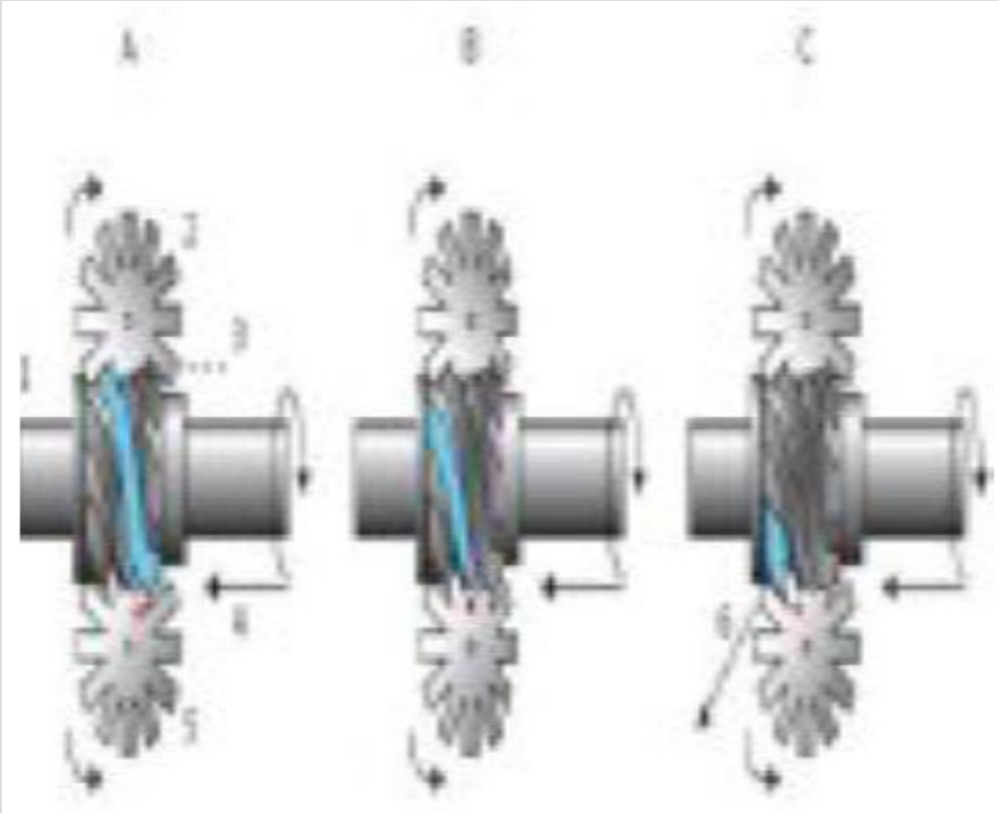

A:Emme
B:Sıkıştırma
C:Boşaltma

1. Vida rotor
2. Dişli rotor A
3. Muhafaza
4. Emme gazı
5. Dişli rotor B
6. Tahliye portu

Bir vidalı kompresörde, kompresör ve motor birbirinden ayrılmıştır ve bu nedenle bir aks veya V-kayışı ile bağlanırlar. Kompresör ve motor ayrı olduğu için, kompresörde soğutucu olarak amonyak kullanılabilir. Soğutma sistemlerinin soğutma çıkışı, kompresör performansı ayarlanarak düzenlenebilir. Bir vidalı kompresör, %100'den neredeyse %0'a kadar sorunsuz şekilde ayar yapılmasını sağladığı için, soğutma sistemlerinin düzenlenmesi için oldukça uygundur.

Turbo (Santrifüj) Kompresör

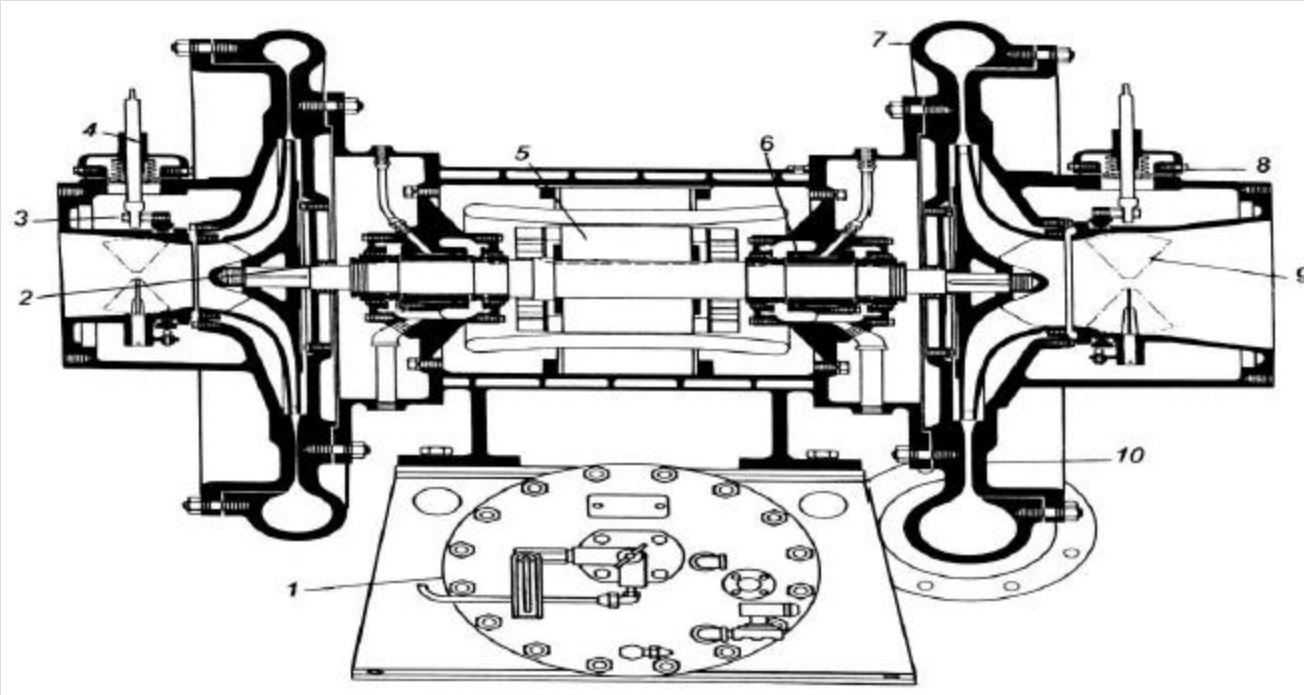

Bu kompresörlerde sıkıştırma dönen çark çevresindeki kanatlar ile sağlanır. Bir çarkta yaklaşık 1.2 oranında sıkıştırma sağlanabildiğinden büyük sıkıştırma oranlarında, art arda çok sayıda çark kullanmak gerekli. Çok fazla çark sayısı istenmediğinden dolayı kademeli kompresörler kullanılır.

Turbo kompresörler düşük basınçlı ve yüksek debili sistemlerde kullanılır.

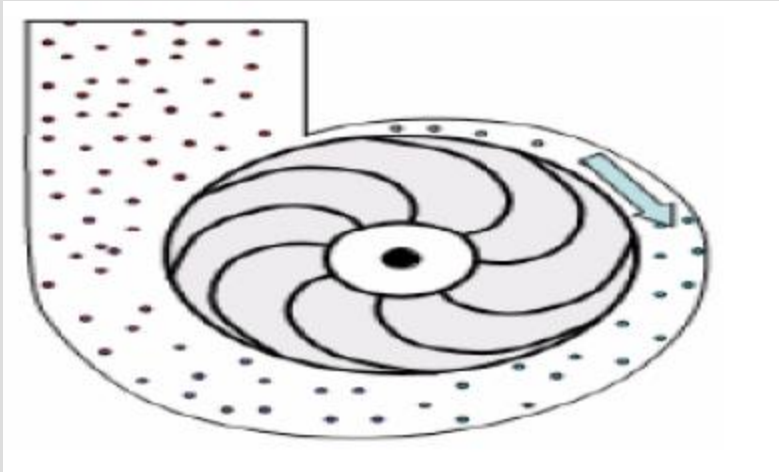

Santrifüj kompresörlerin avantajları şunlardır:

Titreşim yoktur,

Gaz akışı süreklidir,

Soğutma devresinde yağ kaçağı olmaz,
%20 ile %100 arasında güç ayarı

yapılabilir,

İmalat kaliteleri iyidir,

Küçük olmaları nedeniyle , fiyatları daha ucuzdur.

Dezavantajları:

Sıkıştırma oranı düşüktür,

Çok yüksek güçler için uygun değildir,

Motor tarafından açığa çıkarılan ısının geri kazanılması mümkün değildir.

Scroll (Spiralli) Kompresör

Spiral kompresörler, spiral şeklinde iç içe geçmiş iki eleman ile sıkıştırma yapan, yörüngesel hareketli, pozitif yer değiştirme makineleridir.

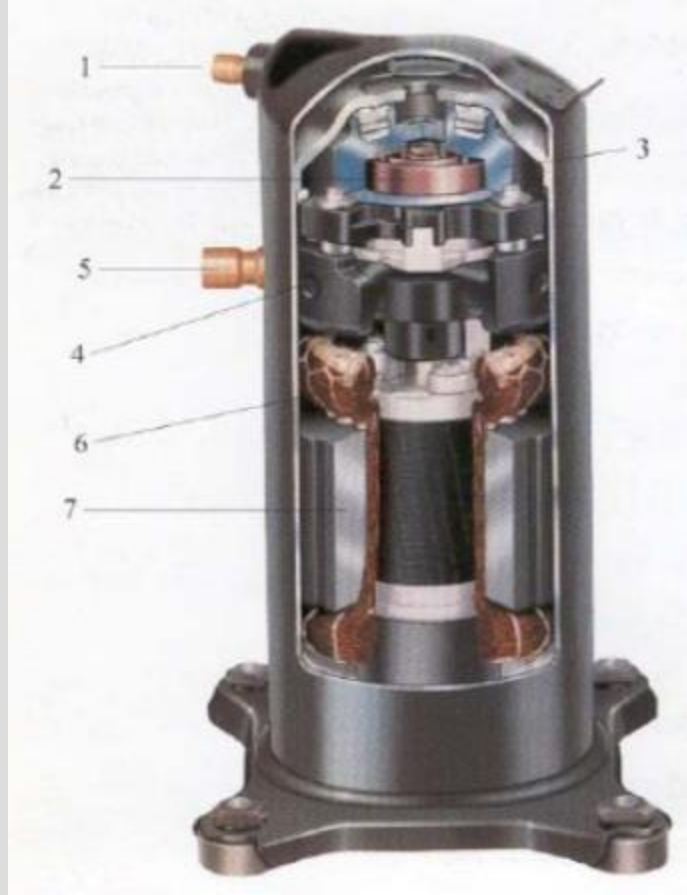
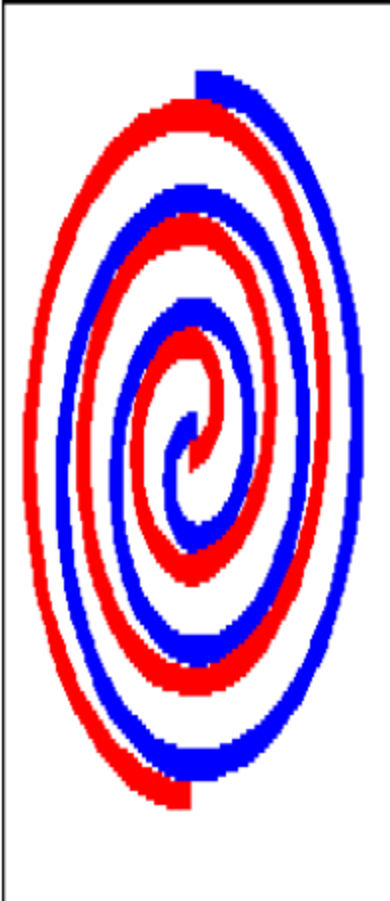

Buharın girişi, scroll'un dış kenarından olurken , çıkış sabit scroll'un merkezinden olmaktadır.scroll kompresörler, pistonlu kompresörlerden nazaran daha az hareketli parçaya sahiptir. Bu yüzden daha sessiz çalışır.

Tahrik Mekanizmasına Göre Hermetik Kompresör:

Kompresör ve elektrik motoru aynı kabın içerisindedir.



Yarı hermetik Kompresör:

Kompresör ve elektrik motoru aynı kaplarda ve direk bağlantılıdır.



Açık Tip Kompresör:

Elektrik motoru ayrı ve kompresör ayrıdır.
Kayış kasa, dişli veya kaplin ile bağlantı yapılır.

KONDANSERLER (YOĞUŞTURUCULAR)

Soğutma sisteminin temel elemanlarından biri olan yoğuşturucular, yüksek basınç ve sıcaklıktaki kızgın buhar haldeki soğutucu akışkanın ısını dış ortama vermek suretiyle sıvı hale gelmesini sağlayan bir elemandır. Yani buharlaştırıcıda aldığı ısı ile buharlaşan ve kompresörde sıkışma işlemi sonucu sıcaklığı ve kızgınlığı artan soğutucu akışkan burada sıvı hale gelir. Yoğuşturucular sistemin yüksek basınç tarafına monte edilirler.

Yoğuşturucunun ısıyı sıcak soğutucu akışkan buharından soğuk ortama atabilme kabiliyeti, yoğuşturucu kapasitesi olarak adlandırılır.

Yoğuşturucunun ısı transfer kapasitesi aşağıdaki dört faktöre bağlıdır:

Yoğuşturucunun yapımında kullanılan malzemeye,
Yoğuşturucu yüzeyi ile yoğuşma ortamı arasındaki temas alanına,
Yoğuşma ortamı ve soğutucu akışkan buharı arasındaki sıcaklık farkına ,
Yoğuşturucunun temizliğine.

Yoğuşturucu, buhar içindeki ısıyı ilk olarak yoğuşturucu tüplerinin cidarlarına ve sonra tüplerden soğuk ortama transfer ederek uzaklaştırır. Soğuk ortam hava, su ve bu ikisinin bir kombinasyonu olarak karşımıza çıkabilir. Şekilde de görüldüğü gibi bu ısı alışverişi üç ana bölgede meydana gelmektedir:

Kızgınlığın alınması i8 yoğuşturucu dizaynına bağılı olarak yoğuşturucu alanının %5 ' i kullanılmaktadır.)

Yoğuşma (yoğuşturucu alanının yaklaşık % 85 ' i kullanılmaktadır.)

Aşırı soğutma (yoğuşturucu alanının %0- 10 'u kullanılmaktadır.)

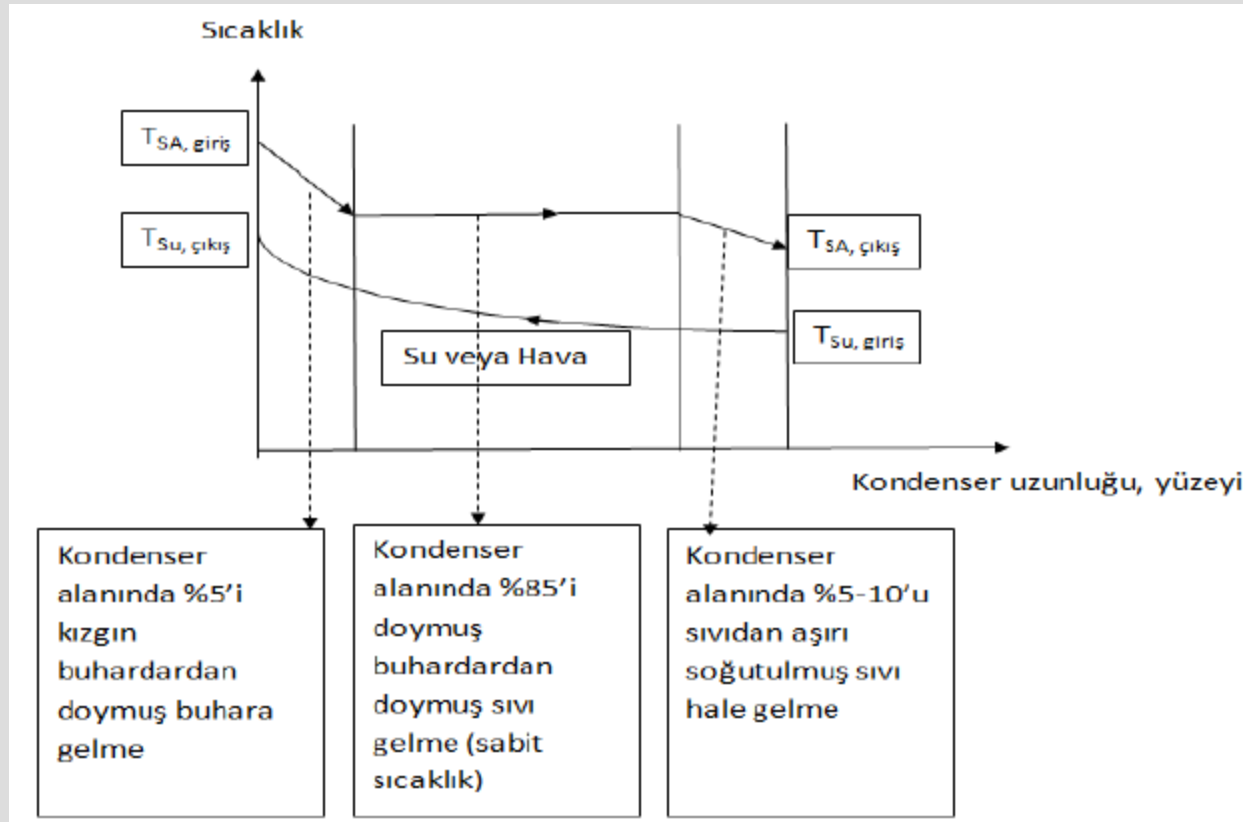

Isı verilen ortama göre yoğuşturucular ikiye ye ayrılır:

a) Hava Soğutmalı Yoğuşturucular

Özellikle 750 W kadar olan kapasitedeki soğutma gruplarında istisnasız denecek şekilde kullanılır. Bu tip yoğuşturucuların tercih sebepleri , basit oluşları, kuruluş ve işletme masraflarının düşüklüğü ,tamir ve bakımlarının kolaylığı sayılabilir.

Hava soğutmalı yoğuşturucular genellikle kanatlı borulu olarak imal edilirler.

Borunun içinde soğutucu akışkan , dışında ise hava geçer.

Bu tip yoğuşturucular daha ziyade küçük soğutma yüklerinde yeterli miktarda soğutma suyu bulunmayan durumlarda kullanılır.

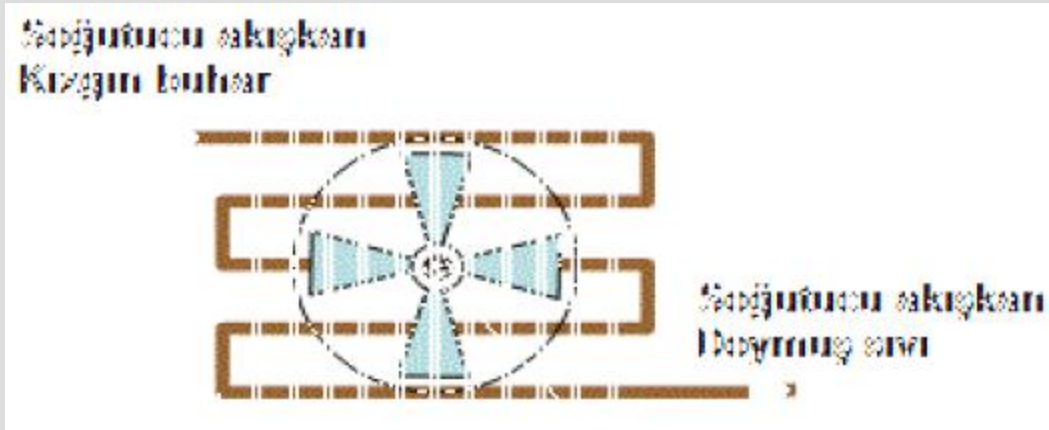



b) Su Soğutmalı Yoğuşurturucular

Su soğutmalı yoğuşurturucularda soğutma ortamı olarak su kullanılır. Ticari ve endüstriyel soğutma sistemlerinde su soğutmalı yoğuşurturucular , hava soğutmalı yoğuşurturuculara göre daha yaygın olarak kullanılır.

Çünkü su soğutmalı yoğuşurturucular aynı kapasitedeki hava yoğuşurturuculardan daha küçüktürler ve bu yüzden daha az yer kaplarlar

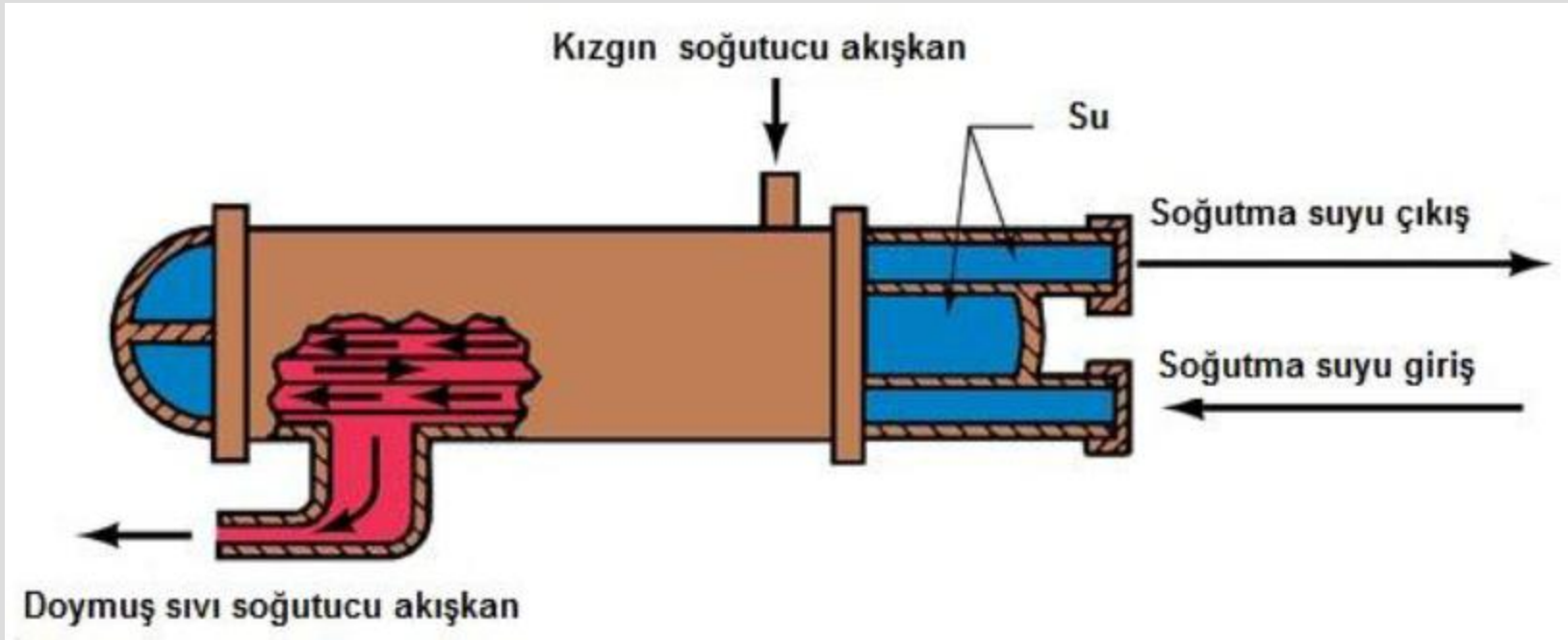

Soğuk su üretici gruplar ve soğutma tesislerinde, soğutucu akışkanın yoğuşturulmasında ve ısı pompalarında sıcak su üretiminde kullanılırlar.



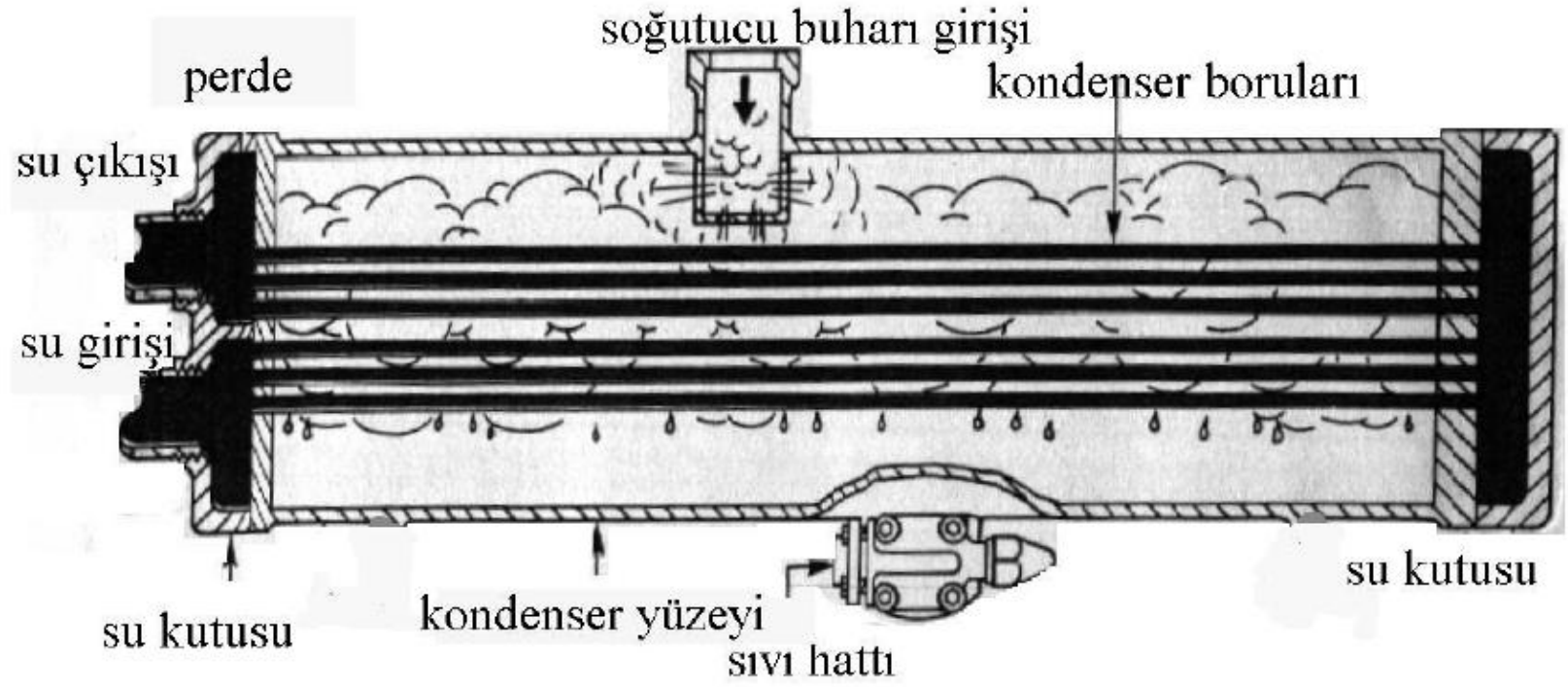
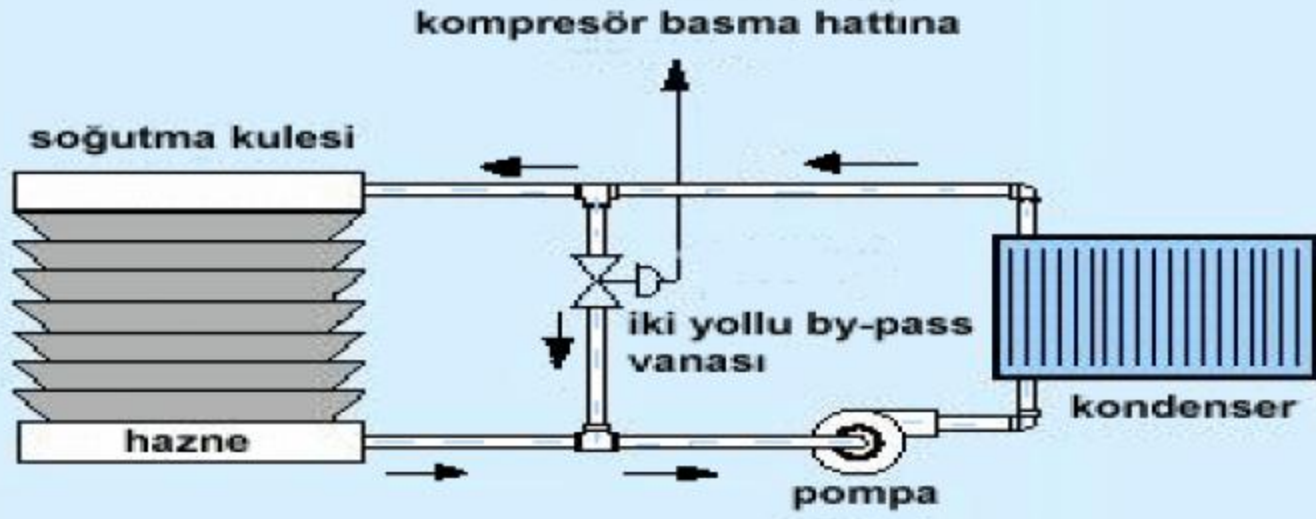

Bir su soğutmalı yoğuşturucu, hava soğutmalı yoğuşturuculara göre daha düşük yoğuşma sıcaklığına sahiptir. Çünkü temin edilen su sıcaklığı normalde çevre havası sıcaklığından düşüktür. Bu yüzden bir su soğutmalı yoğuşturucu için kompresör, aynı kapasite için daha düşük beygir gücüne gereksinim duyar.

Kondenser Tipleri

İç içe (Çift) Borulu Kondenserler

Daha küçük kapasiteler için paket tipi cihazlarda kullanılan bu tip yoğuşturucular hem klima , hem de soğuk muhafaza uygulamalarında kullanılmaktadır. Bu yoğuşturucularda içteki boru içinde su dışında ise soğutucu akışkan bulunur.

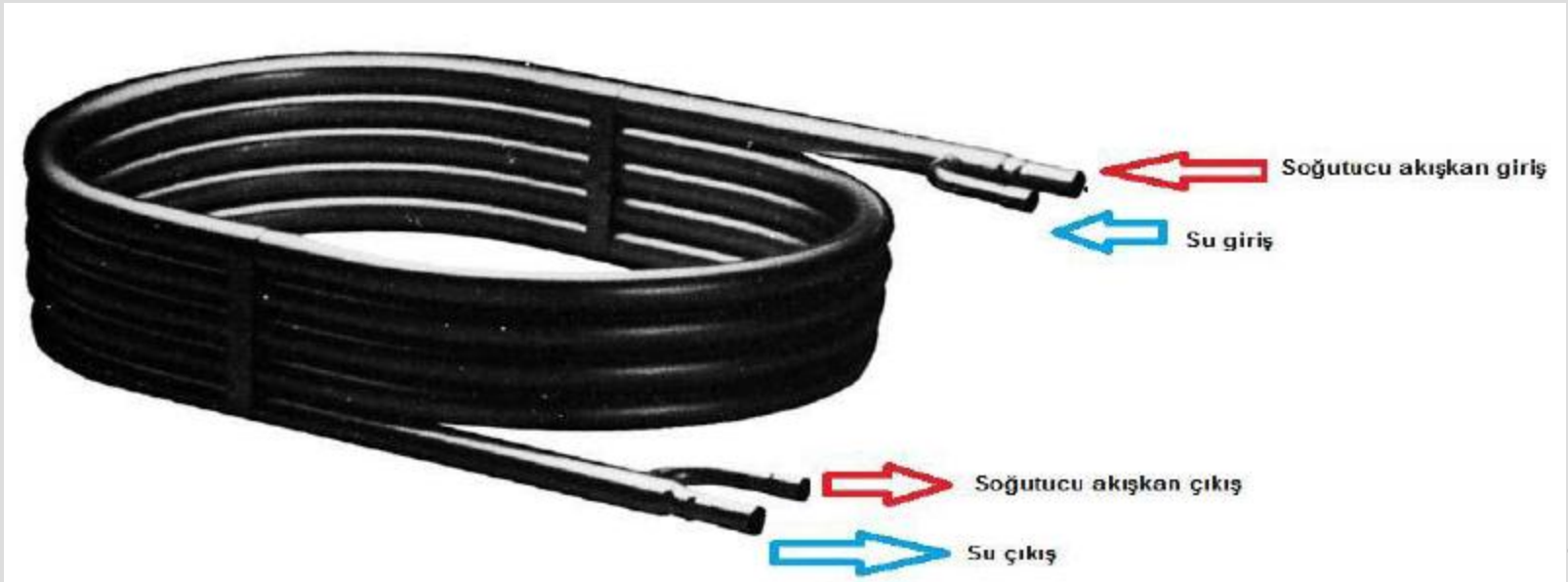



İç içe borulu tip yoğuşturucular

Daldırmalı Tip Kondenseler

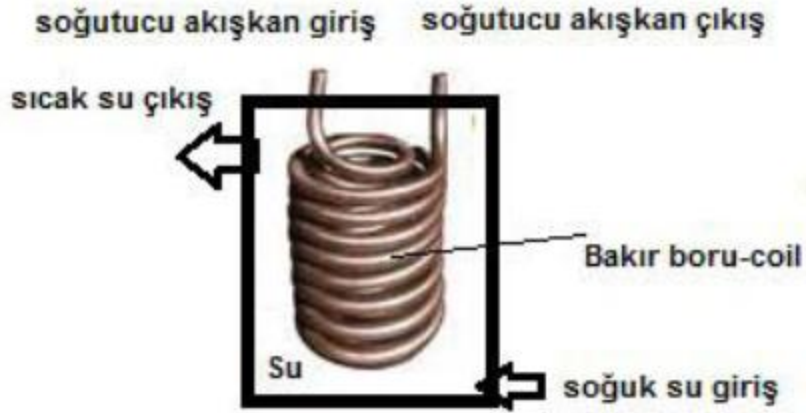
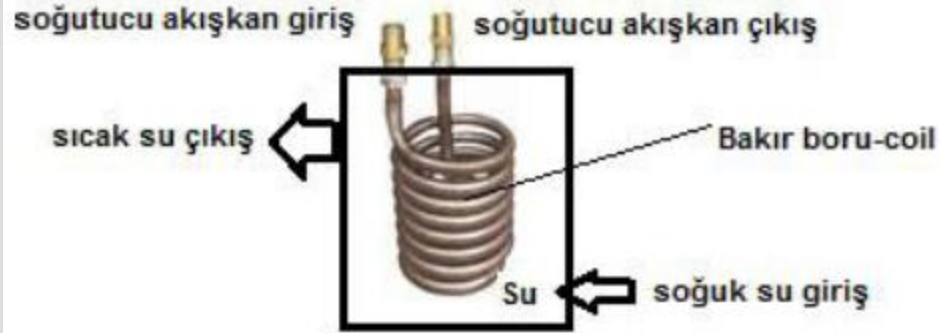

Buharlaştırmalı (Evaporatif) Tip Kondanser

Hava ve suyun soğutma etkisinde birlikte faydalanma esasına dayanan bu yoğuşturucular bakım ve servis güçlükleri , çabuk kirlenmeleri ve sık sık araziye müsait oluşları nedeniyle gittikçe daha az kullanılmaktadır.

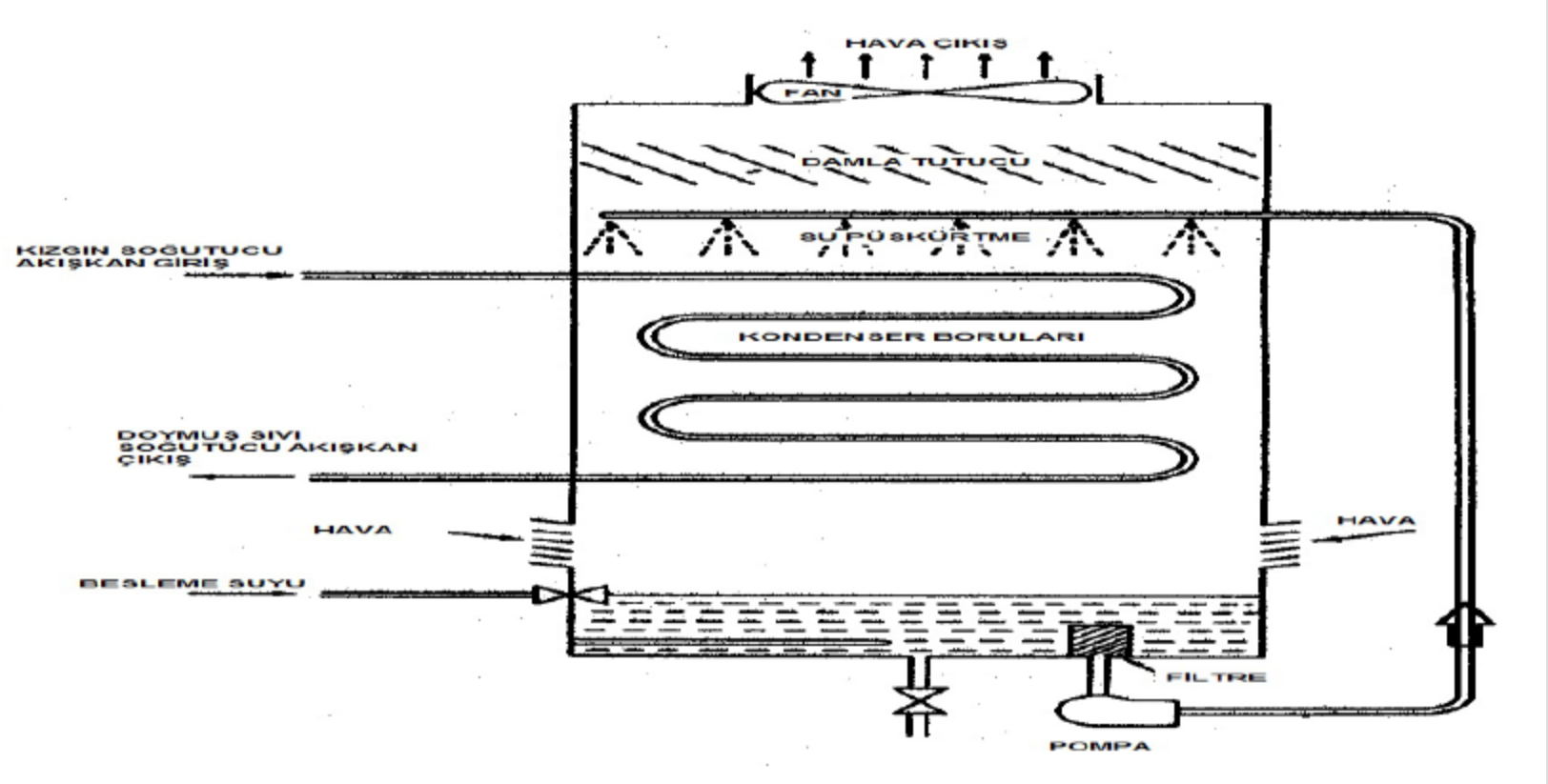

Gövde Borulu Kondanserler

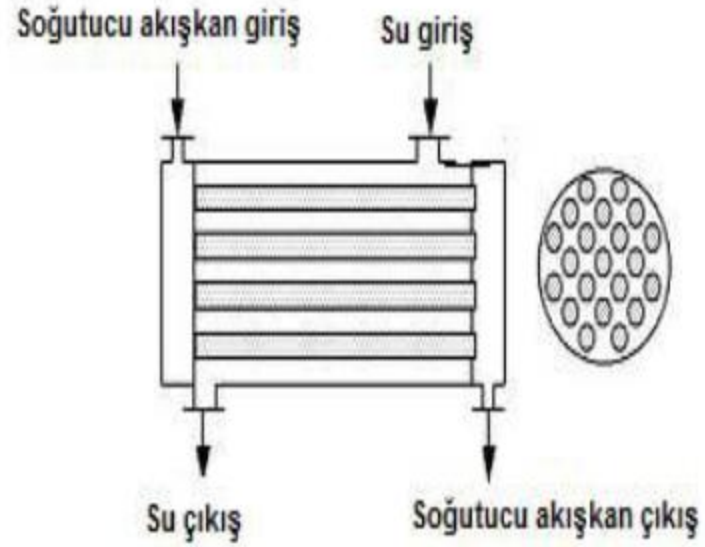

Soğutma Kuleleri

Su soğutma kuleleri, sistemden gelen sıcak suyun dolgu üzerine püskürtülmesi ile ısının atmosfere verilerek ortamdaki sıcaklığın düşürülmesiyle soğuma sağlayan sistemlerdir. Soğutma kulesi bir ısı uzaklaştırma ünitesidir. İçinden geçen suyun bir kısmının buharlaşmasını sağlayarak sistemdeki istenmeyen ısıyı atmosfere verir. Kalan su ise istenilen derecede soğur. Sıcak bir nesnenin üzerine su dökülerek soğuduğunu düşünün. Islak bir yüzeyin soğuması kuruya oranla çok daha hızlıdır. Aynı şekilde, su soğutma kulesi de, kuru tip ısı uzaklaştırma ünitelerinden çok daha etkilidir. Su soğutma kulelerinin yaygın kullanım alanları arasında klima sistemleri, üretim tesisleri ve enerji santralleri vardır.

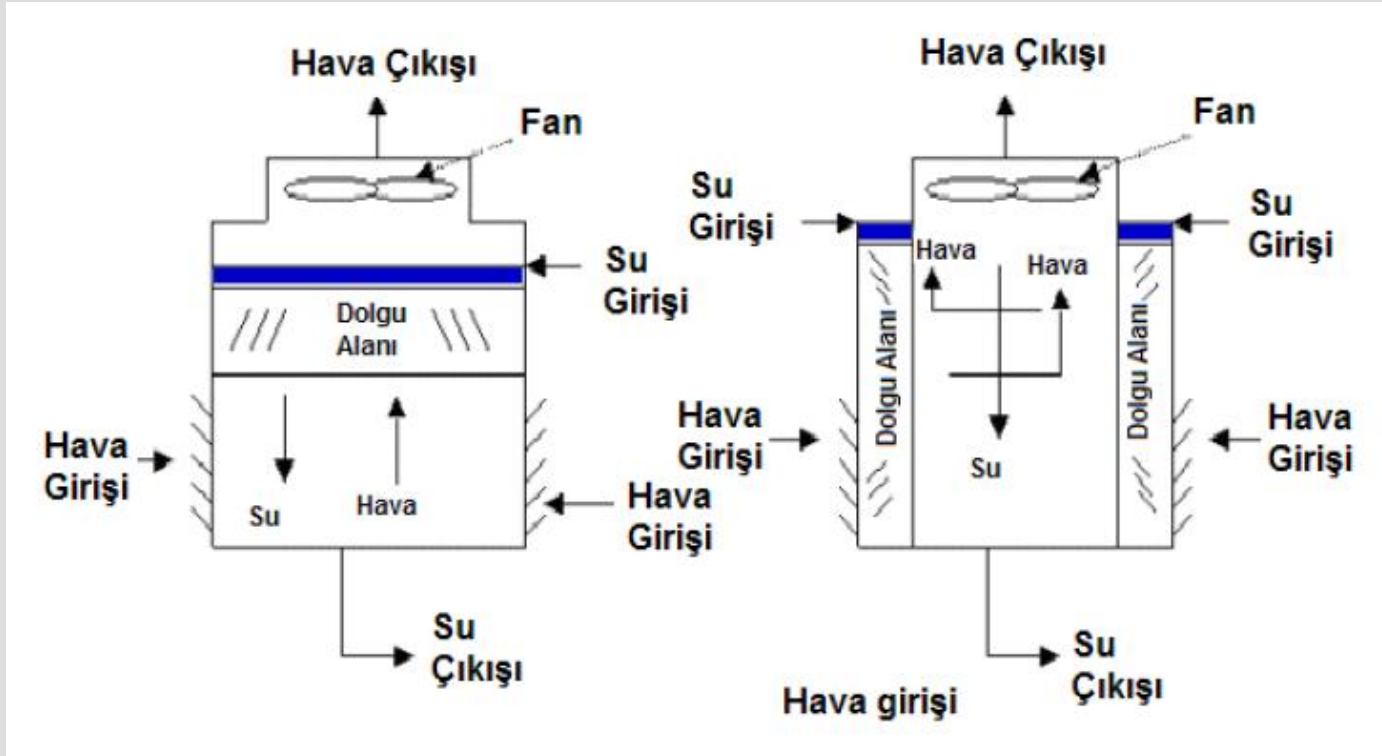

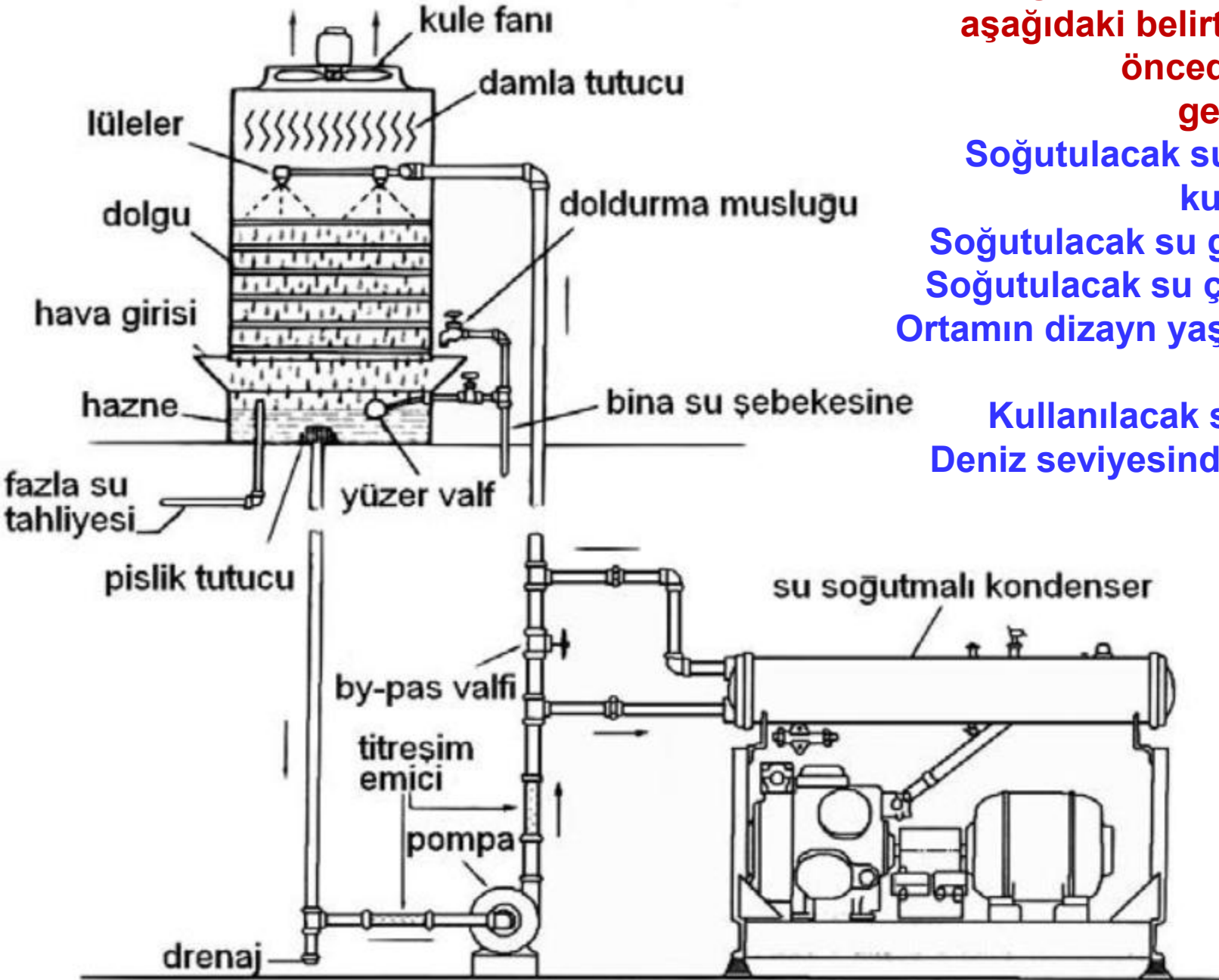

**Soğutma kulesi seçiminde
aşağıdaki belirtilen verilerin
önceden bilinmesi
gerekmektedir:**

**Soğutulacak su debisi veya
kule kapasitesi**

Soğutulacak su giriş sıcaklığı

Soğutulacak su çıkış sıcaklığı

**Ortamın dizayn yaş termometre
sıcaklığı**

Kullanılacak suyun analizi

Deniz seviyesinden yükseklik

Su Soğutma Kulelerinin Sınıflandırılması

- 1-Doğal çekişli ve zorlanmış(cebri) çekişli olarak sınıflandırılabilirler.
- 2-Hava ve su akışının durumuna göre karşı akışlı ve çapraz akışlı su soğutma kuleleri sınıflandırılabilirler.
- 3-Bunun dışında kullanılan fana göre radyal fanlı veya eksenel fanlı su soğutma kulesi olabilir.

Su kulesinde temel elemanlar

- 1-fan
- 2-dolgu malzemesi (tahta veya plastik (pvc))
- 3-damla tutucu
- 4-su haznesi
- 5-ana gövde

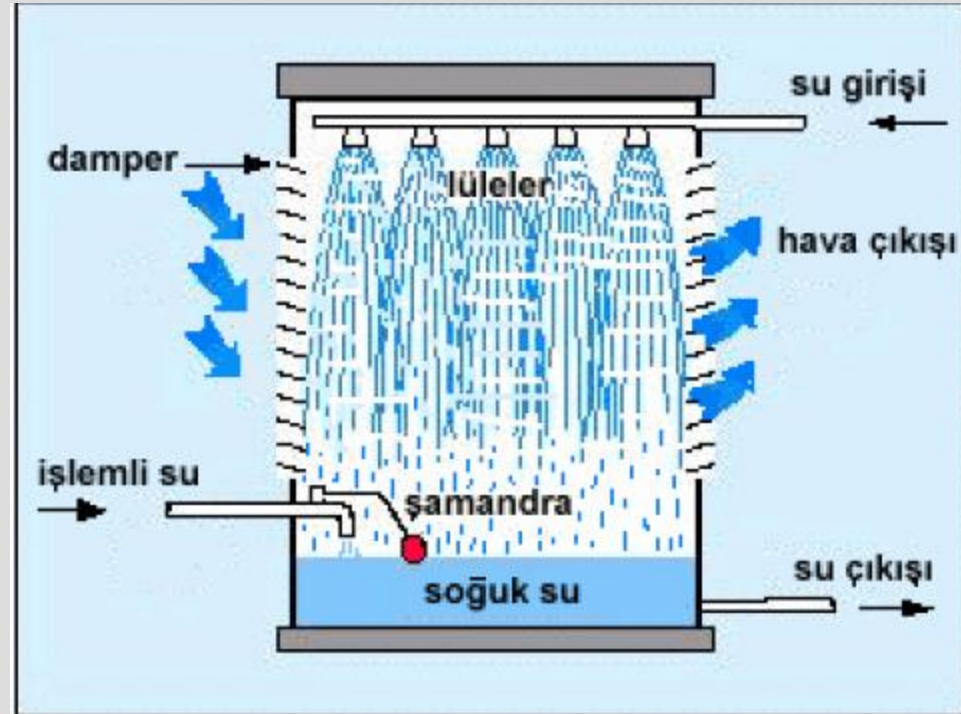

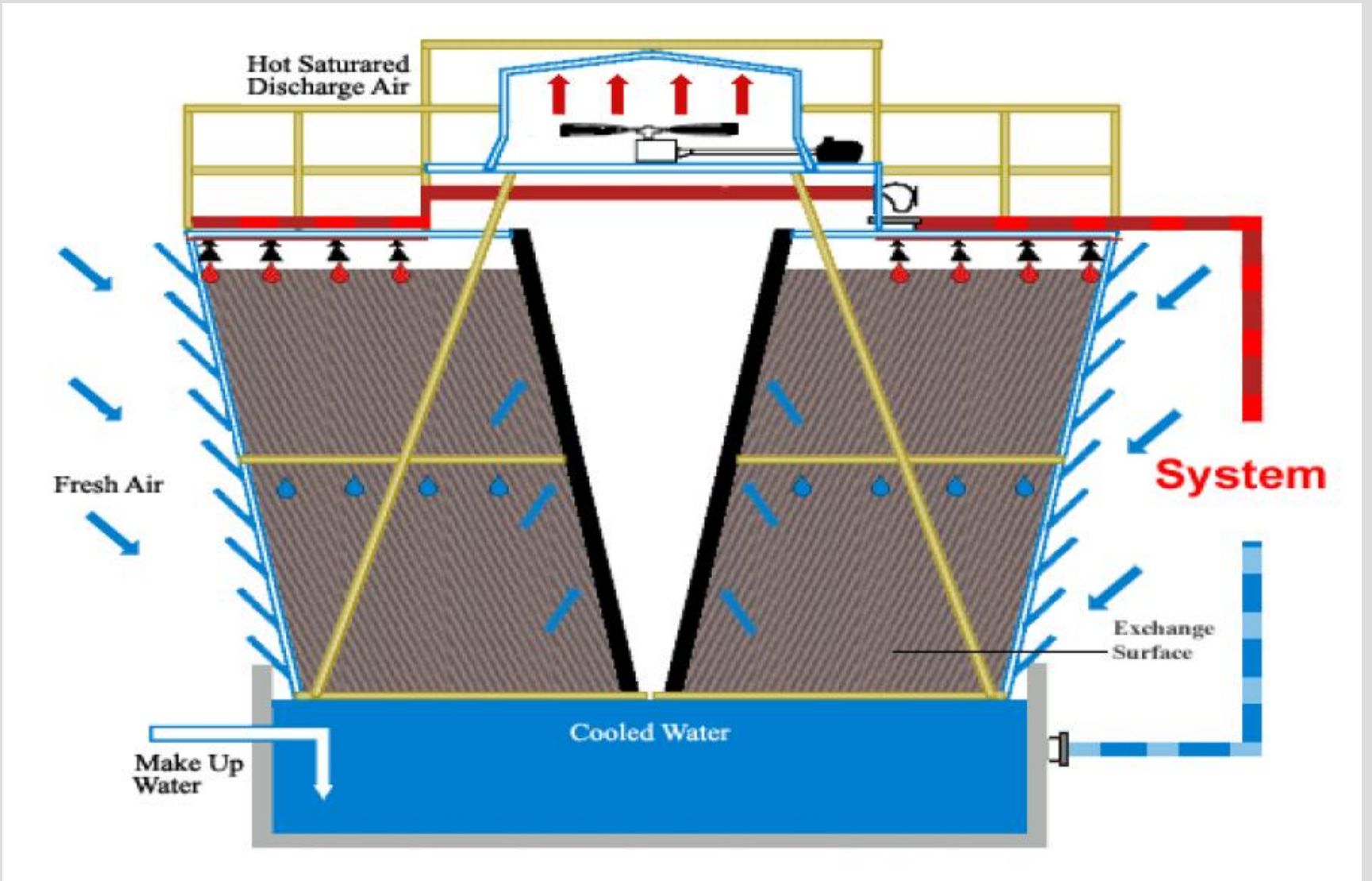

Cebri Çekişli Su soğutma kulesi

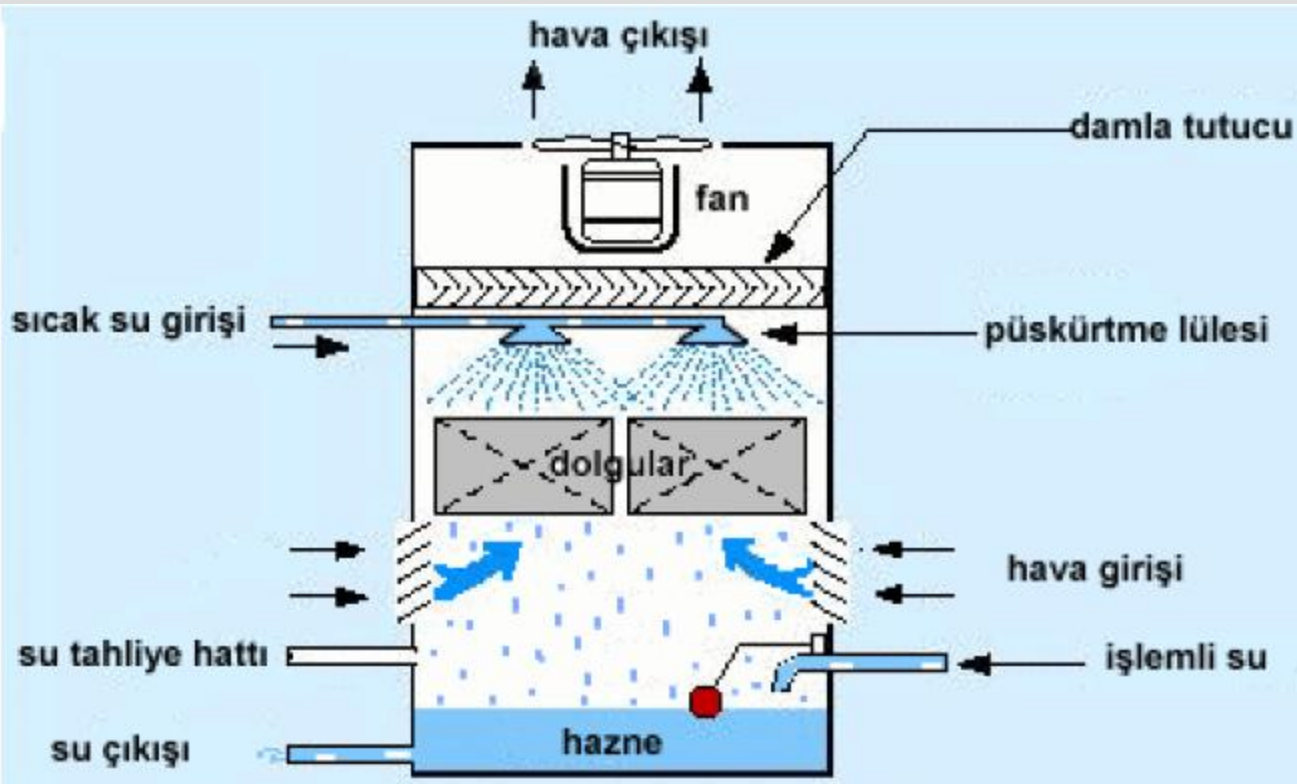

Zorlanmış Çekişli Su Soğutma Kulesi



Eksenel Fanlı Su Soğutma



Radyal Fanlı Su Soğutma

EVAPORATÖRLER (BUHARLAŞTIRICILAR)

Bir soğutma sisteminde Evaporatör, doymuş sıvı-buhar karışımı olarak giren soğutucu akışkanı en az doymuş buhar veya kızgın buhar olarak çıkmasını etraftan ısı çekerek sağlayan bir ısı deęiřtiricisidir. Soğutucu akışkanın buharlaşarak, soğutulmak istenen ortamdaki ısının çekilmesini sağlayan elemanlardır. İklimlendirme ve soğutma sistemlerinde genellikle soğutulmak istenen ortama yerleştirilir. Soğutucu akışkan buharlaşma basıncında olduęu için soğutulmak istenen ortamdaki ısıyı çekerek buharlaşır ve soğutma elde edilir. Kısacası soğutmanın yapıldığı kısımdır.

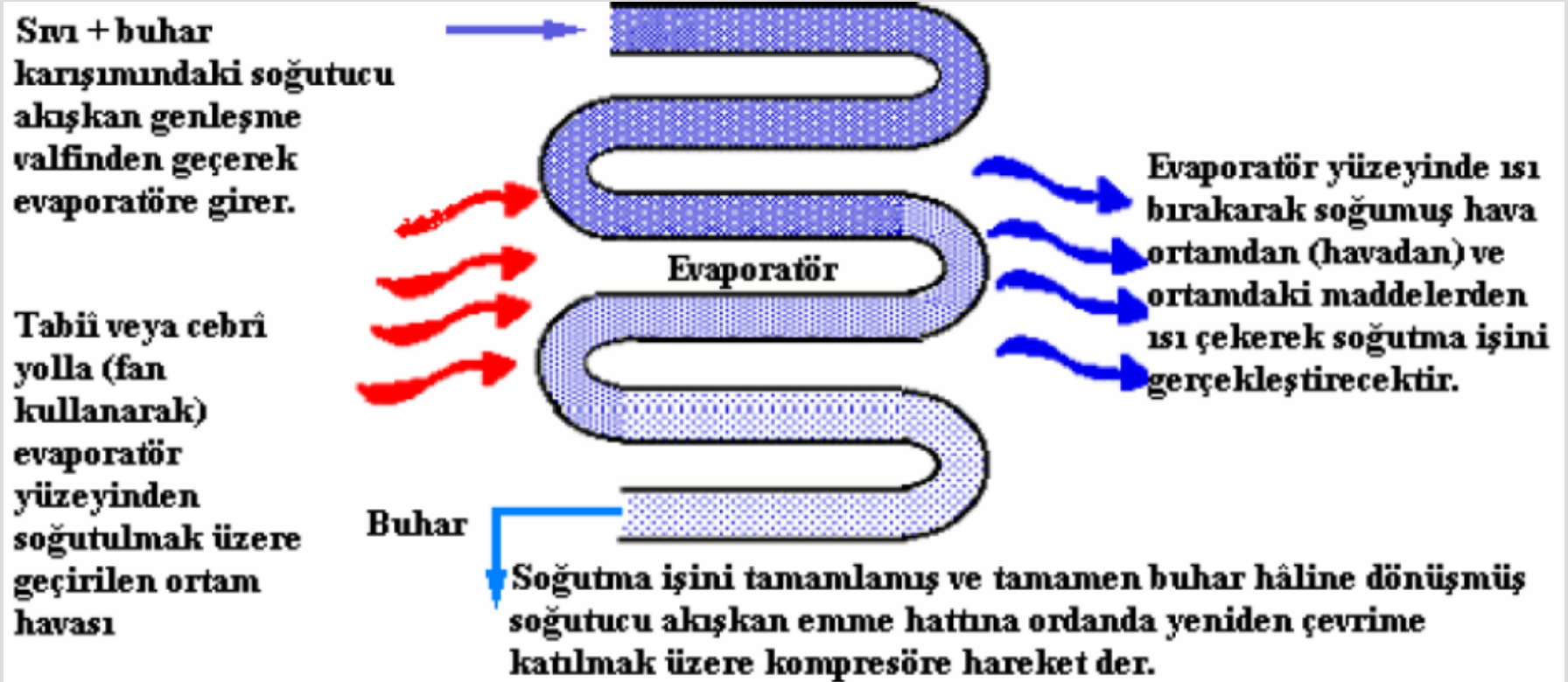

Evaporatör çeşitleri

Çıplak Borulu Evaporatörler

10-22 mm çapında galvaniz kaplı bakır veya çelik borulardan yapılırlar. Borular serpantin şeklinde kıvrılarak bu tür evaporatörler yapılır. Büyük kapasiteli soğutma yüklerinde ve Amonyaklı sistemlerde kullanılır.

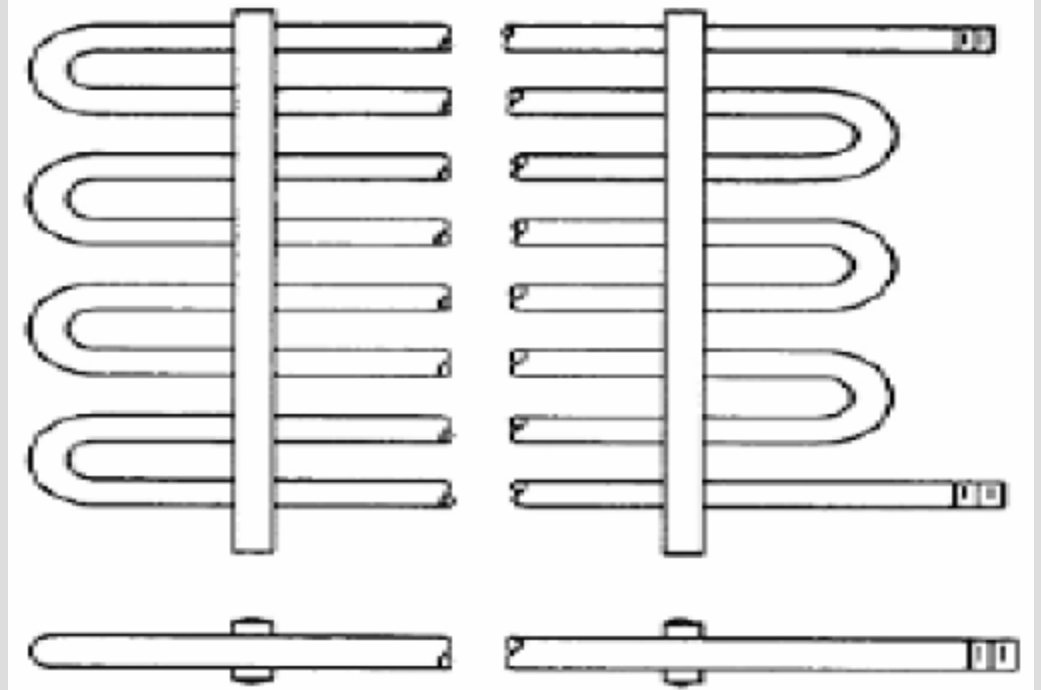

Levhalı Tip Evaporatörler

İki levha üzerine karşılıklı olarak pres baskı yolu ile oyuklar açıldıktan sonra bu levhalar üst üste kaynatılır, böylece arada kalan oluklarla bir buharlaştırıcı serpantini oluşturulmuş olur. Buzdolabı ve vitrin tipi soğutucularda kullanılır.

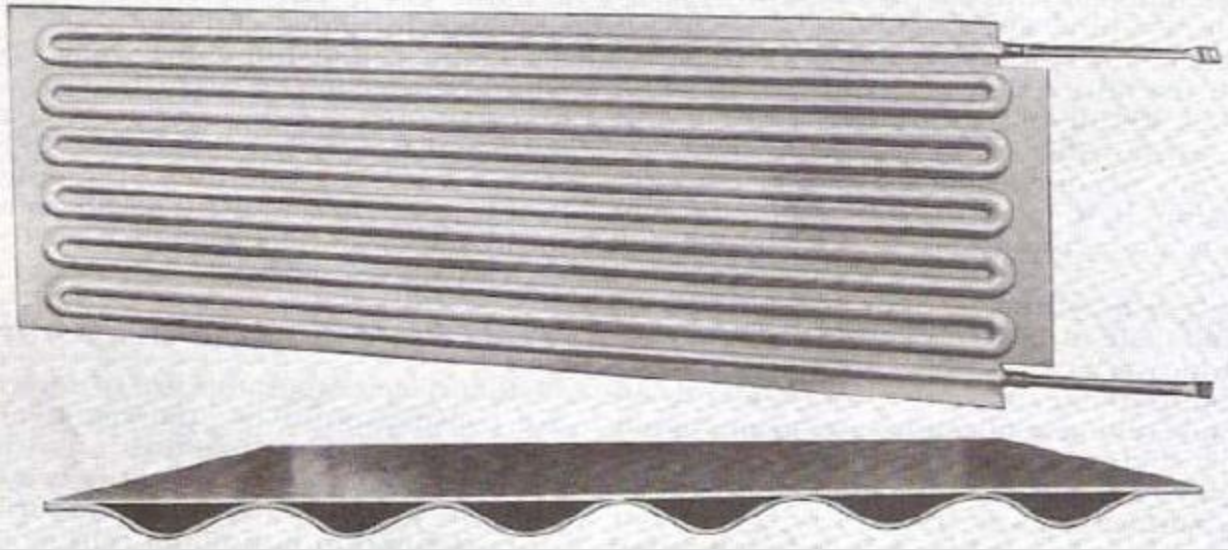

Kanatçıklı Evaporatörler

Hava soğutmak için kullanılırlar.

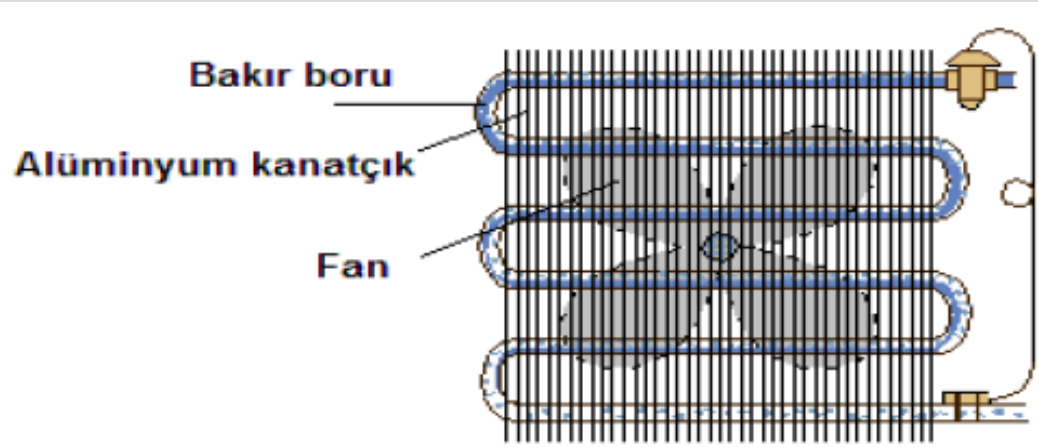

Lamelli Evaporatörler

Serpantin şeklinde kıvrılmış borular üzerine , yüzeyi arttırmak için kanat yerine çubuklar kaynatmak suretiyle yapılır. Daha ziyade küçük soğutma yükleri için bahis konusudur. K değerleri 5- 9.5 kw/m².K arasında değişir. Yüksek değerler zorlanmış taşınım ve bakır boru ile alüminyum çubuk gibi iyi iletken malzemedan yapılmış buharlaştırıcıya aittir. Küçük eğerler ise tersine olarak doğal taşınım ve çelik-çelik buharlaştırıcılar içindir. Ayrıca soğutma sıcaklığı düştükçe K değerinin azalacağıda göz önünde tutulmalıdır.

